

MTC05-30 SERIES

MIL-STD DC/DC Converters: 5 ~30 Watts



Specification

Input

Input Voltage Range	• 15.5-40.0 VDC
Transient Input Range	• 10 VDC for 10 s 50 VDC for 1 s
Turn On	• <15.5 VDC
Turn Off	• <10 VDC
Input Reverse Voltage Protection	• None
Max Input Current	• See table

Output

Output Voltage	• See table
Output Voltage Trim	• See table (not available for dual outputs)
Minimum Load	• No minimum load required
Line Regulation	• $\pm 1\%$ Vout nominal (15.5-40.0 Vin)
Load Regulation	• $\pm 1\%$ Vout nominal
Cross Regulation	• $\pm 3\%$ with 150 mA min load (Dual output only) see longform datasheet for more information
Output Set Tolerance	• ± 100 mV or $\pm 2\%$ whichever is greater
Ripple & Noise	• ≤ 5 Vout: 75 mV pk-pk max, >5 Vout: 1% pk-pk, at max load & 20 MHz bandwidth
Overvoltage Protection	• 110-120% Vout max (15 W & 30 W versions only)
Overcurrent Protection	• 105-150% at nominal input voltage
Short Circuit Protection	• Trip and restart
Overtemperature Protection	• 102 °C to 107 °C, 2 °C to 5 °C hysteresis
Remote Sense	• 0.5 V (Single output only)
Load Step Output Transient	• $< \pm 3\%$ of Vout nom (25-75% load)
Load Step Recovery	• 500 μ s within 1% of nominal value
Line Step Output Transient	• $< \pm 3\%$ of nominal Vout (15.5-40.0 Vin)
Line Step Recovery	• 500 μ s within 1% of nominal value
Start Up Time	• <100 ms
Maximum Capacitive Load	• 300 μ F x Iout max startup within 100 ms

Features

- 10-50 VDC Input Range
- Designed for Vetric & Avionic Use
- Single & Dual Output Versions
- -55 °C Operation Available
- MIL-STD 461 and DEF-STAN 59-411
- MIL-STD 1275 and DEF-STAN 61-5
- 3 Year Warranty

General

Efficiency	• See tables and performance curves
Isolation	• 1500 VDC Input to Output, 1000 VDC Input to Case, 500 VDC Output to Case
Switching Frequency	• Fixed 450 kHz typical
Frequency Synchronization	• 400-500 kHz
Inhibit	• Off = TTL Low or short circuit On = TTL High or open circuit
Power Density	• MTC05: 15.3 W/in ³ , MTC15: 24.4 W/in ³ , MTC30: 14.5 W/in ³
MTBF	• MTC05: 1.7 MHrs, MTC15: 890 kHrs MTC30: 740 kHrs, to MIL-HDBK-217F at +40 °C, GF

Environmental

Case Temperature	• -40 °C to +100 °C, -55 °C to +100 °C extended range 'LT'
Storage Temperature	• -50 °C to +125 °C
Cooling	• Conduction cooling through baseplate
Operating Humidity	• 88% Relative Humidity 240 hrs MIL-STD-810D Method 507.2
Operating Altitude	• Tested to 70000 ft (21336 m)
Shock	• 100 g MIL-STD-810D Method 516.3
Vibration	• 5 to 500 Hz MIL-STD-810D Method 514.3
Bump	• 2000 Bumps in each axis 40 g MIL-STD-810D Method 516.3
Salt Atmosphere	• 48 hrs MIL-STD-810E Method 509.3

Environmental Screening & Low Temperature

All standard products are stress-screened and electrically tested over the operating temperature range. See notes for option details.

EMC

Conducted Emissions	• EN55022 conducted level B* MIL-STD 461E/F CE102* DEF STAN 59-411 DCE01/DCE02*
Immunity	• MIL-STD-704 A*, MIL-STD-704 B-F MIL-STD-1275A/B/C/D*
Conducted Susceptibility	• MIL-STD-461E/F CS101 CS114, CS115, CS116* DEF-STAN 61-5 part 6 issue 5*

* MTF50 Filter Module required to meet these standards

Output Power	Output Voltage			Output Current	Input Current ⁽⁵⁾		Efficiency	Model Number ^(3,4)
	Nominal	Min ⁽¹⁾	Max ⁽¹⁾		No Load	Full Load		
4 W	3.3 VDC	3.3 VDC	4.0 VDC	1.21 A	0.03 A	0.18 A	80%	MTC0528S3V3 [^]
4 W	5.0 VDC	4.0 VDC	6.0 VDC ⁽²⁾	0.80 A	0.02 A	0.19 A	77%	MTC0528S05 [^]
5 W	12.0 VDC	9.0 VDC	13.8 VDC	0.42 A	0.02 A	0.23 A	78%	MTC0528S12 [^]
5 W	15.0 VDC	11.0 VDC	17.0 VDC	0.33 A	0.01 A	0.23 A	77%	MTC0528S15 [^]
5 W	28.0 VDC	20.0 VDC	30.0 VDC	0.18 A	0.02 A	0.22 A	78%	MTC0528S28 [^]

Notes

1. Indicates maximum and minimum voltage adjustment (maximum includes Remote Sense adjustment).
2. The full trim range is not available when the input is <15.5 V.
3. For additional ESS screening, add the suffix '-ESS' to the part number e.g. MTC0528S05-ESS.
4. For -55 °C extended operating range option, add suffix '-LT' to the part number e.g. MTC0528S05-LT.
5. $V_{in} = 28$ VDC.

Mechanical Details

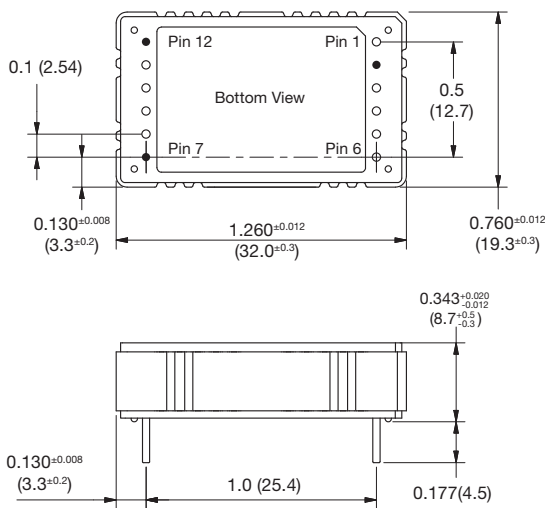

MTC05 Connections	
Pin	Function
1	Case
2	No Pin
3	-Vin
4	+Vin
5	Synchronization
6	Inhibit
7	No Pin
8	Adjust
9	+Sense
10	+Vout
11	-Vout
12	No Pin

Notes.

1. Dimensions are in inches (mm)
2. Tolerance: ±0.02 inches (±0.5 mm) except where indicated.
3. Weight: 0.02 lb (10 g)
4. Materials & Finish:
 - Pin - Diameter: 0.032 (0.8)
Material: Cu Zn30 2.5 µm Ni
Finish: 0.2-0.5 µm AU (HV 170-200)
 - Case - Material: Aluminium (Al Mg Si 0.5)
Finish: Chromated
 - Nameplate - Non-conductive plastic

Accessories

For more information contact sales office or visit www.xppower.com.

- For thermal pad, order model number MTC05 PAD.
- For spacers, order model number MTC05 1 mm SPACER or MTC05 4 mm SPACER.

Efficiency Curves

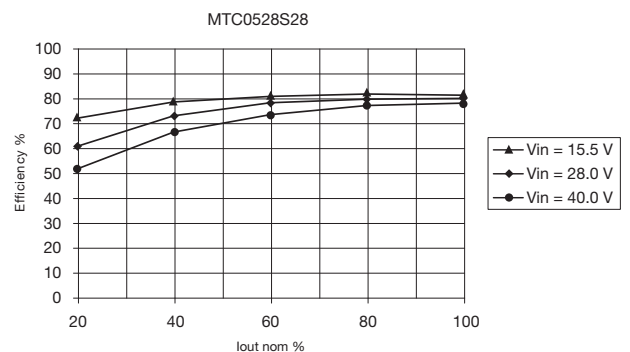
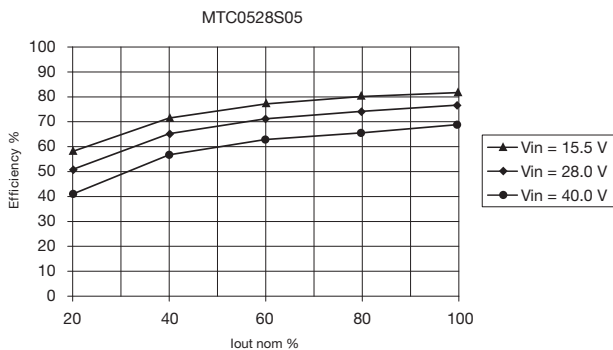

Output Power	Output Voltage			Output Current	Input Current ⁽⁴⁾		Efficiency	Model Number ^(2,3)
	Nominal	Min ⁽¹⁾	Max ⁽¹⁾		No Load	Full Load		
10 W	3.3 VDC	3.3 VDC	4.0 VDC	3.03 A	0.04 A	0.46 A	77%	MTC1528S3V3 [^]
12 W	5.0 VDC	4.0 VDC	6.0 VDC	2.40 A	0.05 A	0.53 A	81%	MTC1528S05 [^]
15 W	12.0 VDC	9.0 VDC	13.8 VDC	1.25 A	0.04 A	0.67 A	80%	MTC1528S12 [^]
15 W	15.0 VDC	11.0 VDC	17.0 VDC	1.00 A	0.05 A	0.67 A	80%	MTC1528S15 [^]
15 W	28.0 VDC	20.0 VDC	30.0 VDC	0.54 A	0.03 A	0.69 A	78%	MTC1528S28 [^]
15 W ⁽⁵⁾	±12 VDC			±1.0 A ⁽⁵⁾	0.03 A	0.68 A	80%	MTC1528D12 [^]
15 W ⁽⁵⁾	±15 VDC			±0.8 A ⁽⁵⁾	0.03 A	0.68 A	80%	MTC1528D15 [^]

Notes

1. Indicates maximum and minimum voltage adjustment (maximum includes Remote Sense adjustment).
2. For additional ESS screening, add the suffix '-ESS' to the part number e.g. MTC1528S05-ESS.
3. For -55 °C extended operating range option, add suffix '-LT' to the part number e.g. MTC1528S05-LT.
4. Typical with $V_{in} = 28$ VDC.
5. Max power 15 W must not be exceeded.

Mechanical Details

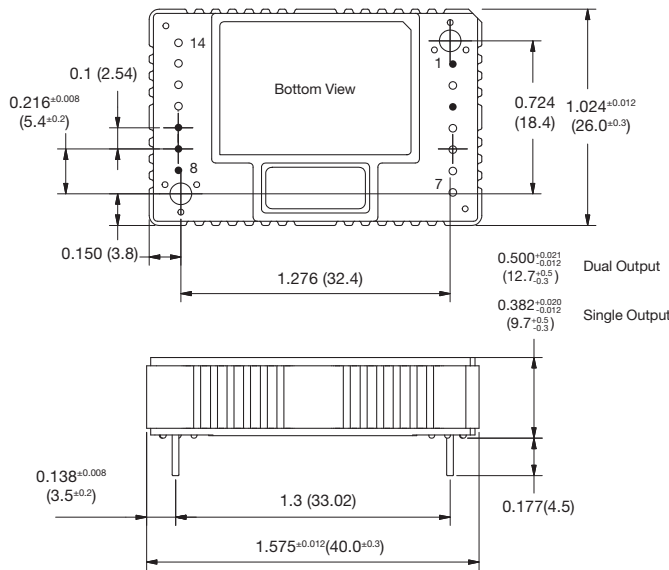

MTC15 Connections		
Pin	Single Output	Dual Output
1	No Pin	No Pin
2	Case	Case
3	No Pin	No Pin
4	- Vin	- Vin
5	Synchronization	Synchronization
6	+ Vin	+ Vin
7	Inhibit	Inhibit
8	No Pin	No Pin
9	No Pin	No Pin
10	No Pin	-Vout
11	+ Sense	No Pin
12	- Vout	COM
13	Adjust	No Pin
14	+ Vout	+ Vout

Notes

1. Dimensions are in inches (mm)
2. Tolerance: ±0.02 inches (±0.5 mm) except where indicated.
3. Weight: 0.04 lb (20 g)
4. Materials & Finish:
 - Pin - Diameter: 0.032 (0.8)
Material: Cu Zn30 2.5 µm Ni
Finish: 0.2-0.5 µm AU (HV 170-200)
 - Mounting Hole - Diameter: 0.102 (2.6)
 - Case - Material: Aluminium (Al Mg Si 0.5)
Finish: Chromated
 - Nameplate - Non-conductive plastic

Accessories

For more information contact sales office or visit www.xppower.com.

- For thermal pad, order model number MTC15 PAD.
- For spacers, order model number MTC15 3 mm SPACER.

Efficiency Curves

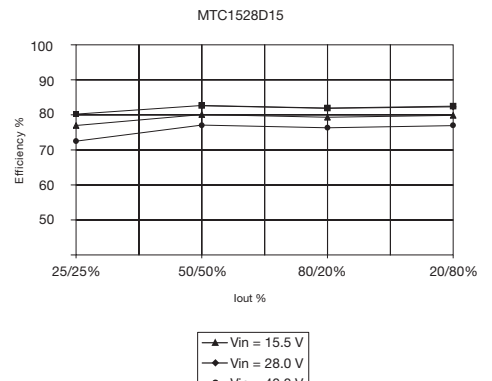
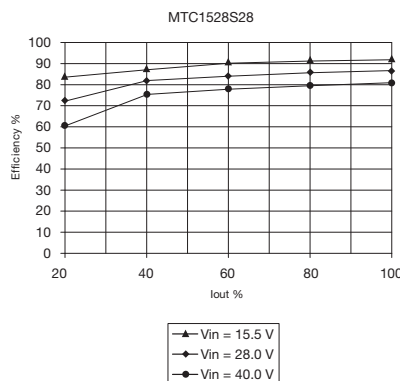
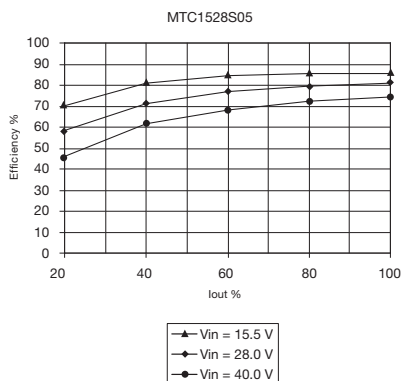

Models and Ratings

Output Power	Output Voltage			Output Current	Input Current ⁽⁶⁾		Efficiency	Model Number ^(3,4)
	Nominal	Min ⁽¹⁾	Max ⁽¹⁾		No Load	Full Load		
20 W	3.3 VDC	3.3 VDC	4.0 VDC	6.06 A	0.06 A	0.89 A	80%	MTC3028S3V3 [^]
25 W	5.0 VDC	4.0 VDC	6.0 VDC	5.00 A	0.09 A	1.08 A	83%	MTC3028S05 [^]
32 W	12.0 VDC	9.0 VDC	13.8 VDC ⁽²⁾	2.70 A	0.05 A	1.41 A	81%	MTC3028S12 [^]
35 W	15.0 VDC	11.0 VDC	17.0 VDC ⁽²⁾	2.33 A	0.06 A	1.54 A	81%	MTC3028S15 [^]
35 W	28.0 VDC	20.0 VDC	30.0 VDC	1.25 A	0.07 A	1.51 A	83%	MTC3028S28 [^]
30 W ⁽⁶⁾	±12 VDC			±2.0 A ⁽⁶⁾	0.04 A	1.33 A	81%	MTC3028D12 [^]
30 W ⁽⁶⁾	±15 VDC			±1.6 A ⁽⁶⁾	0.04 A	1.33 A	80%	MTC3028D15 [^]

Notes

1. Indicates maximum and minimum voltage adjustment (Maximum includes Remote Sense adjustment).
2. The full trim range is not available when the input is <15.5 V.
3. For additional ESS screening, add the suffix '-ESS' to the part number e.g. MTC3028S05-ESS.
4. For -55 °C extended operating range option, add suffix '-LT' to the part number e.g. MTC3028S05-LT.
5. Typical with $V_{in} = 28$ VDC.
6. Max power 30 W must not be exceeded.

Mechanical Details

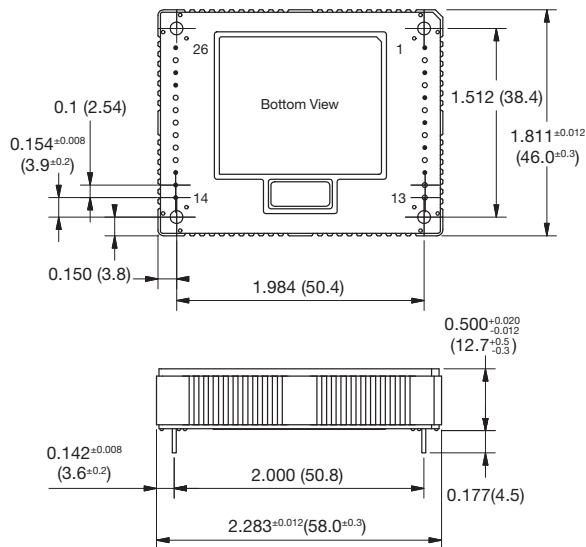

MTC30 Connections		
Pin	Single Output	Dual Output
1	No Pin	No Pin
2	Case	Case
3	No Pin	No Pin
4	- Vin	- Vin
5	No Pin	No Pin
6	+ Vin	+ Vin
7	No Pin	No Pin
8	Synchronization	Synchronization
9	No Pin	No Pin
10	Inhibit	Inhibit
11	No Pin	No Pin
12	Thermal Warning (TW)	Thermal Warning (TW)
13	Signal GND (SGND)	No Pin
14	No Pin	No Pin
15	No Pin	No Pin
16	No Pin	No Pin
17	Adjust	No Pin
18	+ Sense	No Pin
19	+ Vout	+ Vout
20	+ Vout	+ Vout
21	- Vout	COM
22	- Vout	COM
23	No Pin	- Vout
24	No Pin	- Vout
25	- Sense	No Pin
26	No Pin	No Pin

Notes

1. Dimensions are in inches (mm)
2. Tolerance: ±0.02 inches (±0.5 mm) except where indicated.
3. Weight: 0.15 lb (70 g)
4. Materials & Finish:
 - Pin - Diameter: 0.032 (0.8)
Material: Cu Zn30 2.5 μm Ni
Finish: 0.2-0.5 μm AU (HV 170-200)
 - Mounting Hole - Diameter: 0.102 (2.6)
 - Case - Material: Aluminium (Al Mg Si 0.5)
Finish: Chromated
 - Nameplate - Non-conductive plastic

Accessories

For more information contact sales office or visit www.xppower.com.

- For thermal pad, order model number MTC30 PAD.

Efficiency Curves

