

FEC40 SERIES

DC / DC Single, Dual & Triple Output: 40 Watts



Features

- 2:1 Input range: 12V, 24V and 48VDC
- Single, Dual and Triple outputs
- Industry Standard 2 x 2.0in package
- High efficiency up to 90%
- Regulated output & Short circuit protection
- 1600V isolation
- Five sided continuous copper shield
- High operating temperature +85°C
- Fixed switching frequency
- Remote ON / OFF standard (positive logic)
- Optional heat sink: P/N : 7G-0026A.

Specifications:

Input Voltage	12VDC (9 ~ 18) 24VDC (18 ~ 36) 48VDC (36 ~ 75)	Overload Protection	Typically 150% of load
Input Filter	L-C type	Short Circuit protection	Continuous hiccup mode
Input Surge Voltage. (100mS)	12V: 36VDC, 24V: 50VDC, 48V:100VDC	Efficiency	Model dependant 81 ~ 90%
Input Reflected Ripple Current	40mA pk-pk @ nominal input & 100% load	Isolation	1600VDC
Start Up time	25mS constant resistive load	Isolation Cap.	1000pF
Remote ON/OFF (Positive logic)	DC-DC ON Open or 3.5V < Vr < 12V DC-DC OFF Short or 0V < Vr < 1.2V Input current of remote control pin: 0.5mA Remote off state input current: 2.5mA	Switching Freq.	300KHz
Output power	40 watts	Safety	EN60950-1, UL60950-1
Voltage Accuracy	Single & Dual ±1.0% Auxiliary: ±5%	Case Material	Nickel-coated copper
Voltage Trim	Single & Dual only: ±10% via external resistor network. Excludes dual positive and triple output models.	Base Material	Non-conductive black plastic
Minimum Load	See table	Potting	Epoxy UL94-V0
Line Regulation	Single & Dual: ±0.5% Triple Main: ±1% Triple Aux: ±5%	Dimensions	50.8 x 50.8 x 10.2mm
Load Regulation	Single ±0.5% , Dual ±1% Triple Main: ±2%, Triple Aux: ±5%	Weight	60g
Cross Regulation	Triple main: ±1% Dual , Triple, Aux: ±5% Asymmetrical load: Min load-100% load	MTBF	1.398 x 10 ⁶ Hrs
Ripple & noise	Model dependent 50-150mV 20MHZ bandwidth	Operating Temp	-40°C to +85°C (with derating)
Temp. Coefficient	±0.02% / °C	Case Temp	+100°C maximum case temperature
Transient Response	250uS (25% load step change)	Thermal Impedance	9.2°C / watt Standard convection 7.6°C / watt with 20LFM & optional heatsink 2.8°C / watt with 500LFM & optional heatsink
Over Voltage Protection	1.5V ~ 3.3V: 3.9V: 5.0V: 6.2V 12V: 15V 15V: 18V	Thermal shock	MIL-STD-810F
		Vibration	10-55Hz, 10G, 30min along X, Y,Z
		Humidity	5-95% RH
		EMC	EN55022 Class A Consult office for Class B design
		ESD	EN61000-4-2
		Radiated Immunity	EN61000-4-3
		Fast Transients	EN61000-4-4
		Surge	EN61000-4-5
		Conducted Immunity	EN61000-4-6

FEC40 SERIES

DC / DC Single, Dual & Triple Output: 40 Watts

Model	Input V	Output V	Output Current		Input Current		Eff (%)	Capacitor Load max
			Min. load	Full load	No load	Full load		
FEC40-12S1P5	9 – 18 V	1.5 V	0mA	8000mA	110mA	1250mA	84	45000uF
FEC40-12S1P8	9 – 18 V	1.8 V	0mA	8000mA	110mA	1538mA	82	37700uF
FEC40-12S2P5	9 – 18 V	2.5 V	0mA	8000mA	110mA	2083mA	84	27000uF
FEC40-12S3P3	9 – 18 V	3.3 V	0mA	8000mA	175mA	2683mA	86	21000uF
FEC40-12S05	9 – 18 V	5 V	0mA	8000mA	225mA	4065mA	86	13600uF
FEC40-12S12	9 – 18 V	12 V	0mA	3333mA	255mA	4065mA	86	2360uF
FEC40-12S15	9 – 18 V	15 V	0mA	2666mA	310mA	4015mA	87	1510uF
FEC40-12D12	9 – 18 V	± 12 V	± 144mA	± 1800mA	30mA	4444mA	85	± 1200uF
FEC40-12D15	9 – 18 V	± 15 V	± 112mA	± 1400mA	35mA	4321mA	85	± 750uF
FEC40-12D3305	9 – 18 V	3.3 / 5 V	0mA	4A / 4A (total 8A) ⁽¹⁶⁾	325mA	3416mA	85	11000 / 6800uF
FEC40-12T3312	9 – 18 V	3.3 / ±12 V	600mA / ±40mA	6000mA / ±400mA	215mA	3063mA	84	13000 / ±330uF
FEC40-12T3315	9 – 18 V	3.3 / ±15 V	600mA / ±30mA	6000mA / ±300mA	230mA	3000mA	84	13000 / ±110uF
FEC40-12T0512	9 – 18 V	5 / ±12 V	600mA / ±40mA	6000mA / ±400mA	280mA	4024mA	86	6800 / ±330uF
FEC40-12T0515	9 – 18 V	5 / ±15 V	600mA / ±30mA	6000mA / ±300mA	255mA	3963mA	86	6800 / ±110uF
FEC40-24S1P5	18 – 36 V	1.5 V	0mA	8000mA	40mA	649mA	81	45000uF
FEC40-24S1P8	18 – 36 V	1.8 V	0mA	8000mA	40mA	759mA	83	37700uF
FEC40-24S2P5	18 – 36 V	2.5 V	0mA	8000mA	40mA	1016mA	86	27000uF
FEC40-24S3P3	18 – 36 V	3.3 V	0mA	8000mA	60mA	1325mA	87	21000uF
FEC40-24S05	18 – 36 V	5 V	0mA	8000mA	80mA	1961mA	89	13600uF
FEC40-24S12	18 – 36 V	12 V	0mA	3333mA	70mA	2048mA	88	2360uF
FEC40-24S15	18 – 36 V	15 V	0mA	2666mA	85mA	1985mA	89	1510uF
FEC40-24D12	18 – 36 V	± 12 V	± 144mA	± 1800mA	20mA	2169mA	87	± 1200uF
FEC40-24D15	18 – 36 V	± 15 V	± 112mA	± 1400mA	20mA	2108mA	87	± 750uF
FEC40-24D3305	18 – 36 V	3.3 / 5 V	0mA	4A / 4A (total 8A) ⁽¹⁶⁾	80mA	1689mA	86	11000 / 6800uF
FEC40-24T3312	18 – 36 V	3.3 / ±12 V	600mA / ±40mA	6000mA / ±400mA	65mA	1512mA	85	13000 / ±330uF
FEC40-24T3315	18 – 36 V	3.3 / ±15 V	600mA / ±30mA	6000mA / ±300mA	65mA	1481mA	85	13000 / ±110uF
FEC40-24T0512	18 – 36 V	5 / ±12 V	600mA / ±40mA	6000mA / ±400mA	60mA	1989mA	87	6800 / ±330uF
FEC40-24T0515	18 – 36 V	5 / ±15 V	600mA / ±30mA	6000mA / ±300mA	75mA	1958mA	87	6800 / ±110uF
FEC40-48S1P5	36 – 75 V	1.5 V	0mA	8000mA	25mA	321mA	82	45000uF
FEC40-48S1P8	36 – 75 V	1.8 V	0mA	8000mA	25mA	375mA	84	37700uF
FEC40-48S2P5	36 – 75 V	2.5 V	0mA	8000mA	25mA	508mA	86	27000uF
FEC40-48S3P3	36 – 75 V	3.3 V	0mA	8000mA	35mA	655mA	88	21000uF
FEC40-48S05	36 – 75 V	5 V	0mA	8000mA	40mA	969mA	90	13600uF
FEC40-48S12	36 – 75 V	12 V	0mA	3333mA	50mA	1000mA	89	2360uF
FEC40-48S15	36 – 75 V	15 V	0mA	2666mA	50mA	992mA	89	1510uF
FEC40-48D12	36 – 75 V	± 12 V	± 144mA	± 1800mA	15mA	1084mA	87	± 1200uF
FEC40-48D15	36 – 75 V	± 15 V	± 112mA	± 1400mA	15mA	1054mA	87	± 750uF
FEC40-48D3305	36 – 75 V	3.3 / 5 V	0mA	4A / 4A (total 8A) ⁽¹⁶⁾	45mA	823mA	88	11000 / 6800uF
FEC40-48T3312	36 – 75 V	3.3 / ±12 V	600mA / ±40mA	6000mA / ±400mA	35mA	747mA	86	13000 / ±330uF
FEC40-48T3315	36 – 75 V	3.3 / ±15 V	600mA / ±30mA	6000mA / ±300mA	35mA	732mA	86	13000 / ±110uF
FEC40-48T0512	36 – 75 V	5 / ±12 V	600mA / ±40mA	6000mA / ±400mA	30mA	982mA	88	6800 / ±330uF
FEC40-48T0515	36 – 75 V	5 / ±15 V	600mA / ±30mA	6000mA / ±300mA	40mA	967mA	88	6800 / ±110uF

Note

1. MTBF as per BELLCORE TR-NWT-000332. Case I: 50% Stress, Temperature at 40°C. (Ground fixed and controlled environment).
2. Typical values at nominal input voltage and full resistive load.
3. The output requires minimum loading on the output to maintain specified regulation. Operation in no-load condition will not damage these devices, however they may not meet all listed specification.
4. For the single output: Maximum output deviation is 10% inclusive of remote sense and trim. If remote sense is not being used, the +V sense **should be** connected to its corresponding +OUTPUT and likewise the sense should be connected to its corresponding –OUTPUT.
5. Load regulation for triple output:
Main output(V1):10 to 100% with 10% to 100% balanced on auxiliaries.
Auxiliary outputs(V2 and V3):10% to 100% balanced on all outputs.
6. Cross regulation for dual output: asymmetrical load 25% / 100% FL.
Cross regulation for triple output: Main output 100% load, Auxiliary 100%, other auxiliary 25% to 100%.
Auxiliary outputs(V2 and V3):main output 100% load, auxiliary 100%, other auxiliary 25% to 100% or main output 25%,auxiliary 25%, other auxiliary 25% to 100%.
7. The models of FEC40-XXD3305 are specified with a 1uF ceramic output capacitors.
8. Switching frequency for dual output: master (5Vo) 300KHz slave (3.3Vo) 500KHz
9. The ON/OFF control pin voltage is referenced to -Vin.
10. Heat sink is optional and **P/N : 7G-0026A.**
11. The FEC40 series can meet EN55022 Class A with parallel an external capacitor to the input pins.
Recommend: 12Vin : 6.8µF/50V 1812 MLCC . ; 24Vin : 6.8µF/50V 1812 MLCC . 48Vin : 2.2µF/100V 1812 MLCC.
12. An external filter capacitor is required if the module has to meet EN61000-4-5.
Filter capacitor recommended: Nippon chemi-con KY series, 220µF/100V, ESR 48mΩ.
13. Any condition of dual output (3.3V/5V) rated output current, not to exceed 8A of total output currents.

FEC40 SERIES

DC / DC Single, Dual & Triple Output: 40 Watts

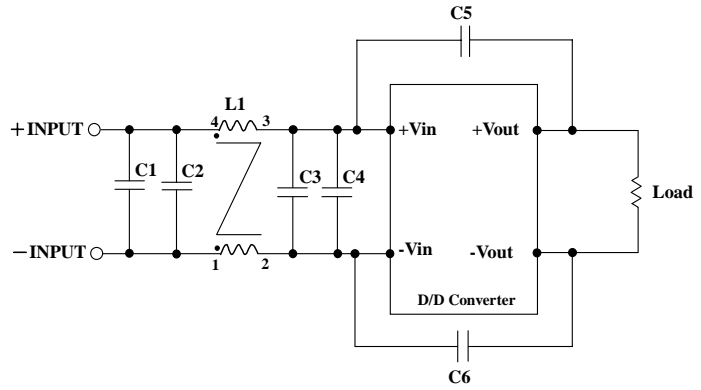
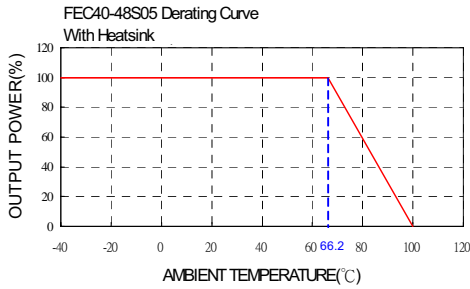
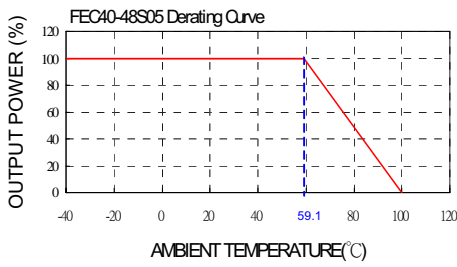

Recommended Filter for EN55022 Class B Compliance

The components used in the above figure, together with the manufacturers' part numbers for these components, are as follows:

	C1	C2	C3	C4	C5 & C6	L1
FEC40-12xxx	4.7uF/50V 1812 MLCC	N/A	4.7uF/50V 1812 MLCC	N/A	1000pF/2KV MLCC	450uH Common Choke PMT-048
FEC40-24xxx	6.8uF/50V 1812 MLCC	N/A	6.8uF/50V 1812 MLCC	N/A	1000pF/2KV MLCC	450uH Common Choke PMT-048
FEC40-48xxx	2.2uF/100V 1812 MLCC	2.2uF/100V 1812 MLCC	2.2uF/100V 1812 MLCC	2.2uF/100V 1812 MLCC	1000pF/2KV MLCC	830uH Common Choke PMT-053

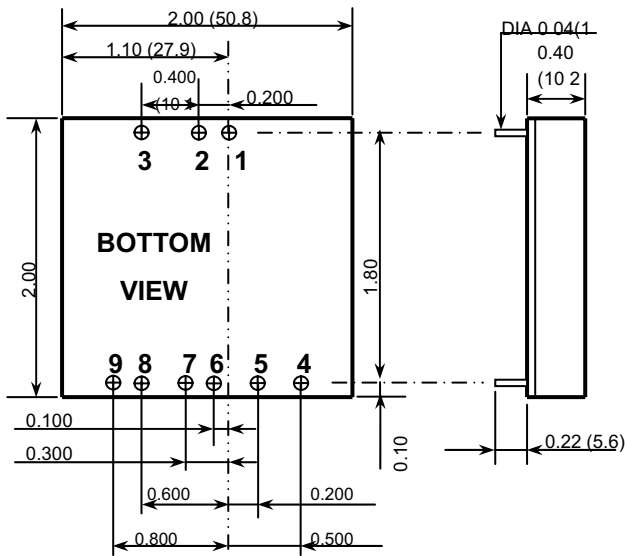

- All dimensions in Inches (mm)
Tolerance: X.XX±0.02 (X.X±0.5)
X.XXX±0.01 (X.XX±0.25)
- Pin pitch tolerance ±0.01(0.25)
- Pin dimension tolerance ±0.004 (0.1)

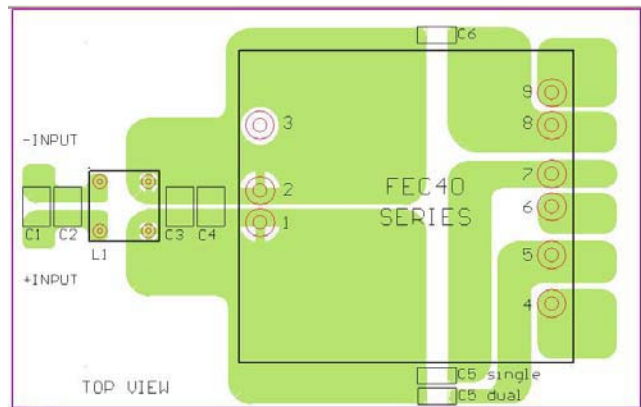

Recommended EN55022 Class B Filter Circuit Layout

Pin Assignment				
PIN	SINGLE	DUAL	DUAL POSITIVE	TRIPLE
1	+ INPUT	+ INPUT	+ INPUT	+ INPUT
2	- INPUT	- INPUT	- INPUT	- INPUT
3	CTRL	CTRL	CTRL	CTRL
4	NC	NO PIN	3.3V	+ AUX
5	- SENSE (Note 4)	+ VO	3.3V RTN (COM)	COMMON
6	+ SENSE (Note4)	COM	NC	- AUX
7	+ OUTPUT	COM	NC	+ OUTPUT
8	- OUTPUT	- VO	5V	- OUTPUT (COM)
9	TRIM	TRIM	5V RTN (COM)	NC

EXTERNAL OUTPUT TRIMMING

Output can be externally trimmed by using the method shown below.
() for dual output trim

