

# ECM40-100 SERIES

AC/DC Single & Multi Output: 40 ~ 100 Watts



## Specification

### Input

Input Voltage	• 90-264 VAC (120-370 VDC)
Input Frequency	• 47-63 Hz; 440 Hz*
Input Current	• 40 W: 0.4 A max at 230 VAC 60 W: 0.6 A max at 230 VAC 100 W: 0.9 A max at 230 VAC
Inrush Current	• 40 A max at 230 VAC
Earth Leakage Current	• <125 $\mu$ A at 115 VAC/60 Hz <210 $\mu$ A at 230 VAC/50 Hz
Power Factor	• EN61000-3-2
Input Protection	• Internal T3.15 A, 250 V fuse in line and neutral

### Output

Output Voltage	• See tables
Output Voltage Trim	• $\pm$ 5% on 3.3 V & 5 V versions, $\pm$ 10% on other single output models and V1 of multi-output models. (See note 1 for ECM40/60 models)
Initial Set Accuracy	• $\pm$ 1.0% V1, $\pm$ 5% V2, V3 & V4
Minimum Load	• See tables
Start Up Delay	• 1.5 s max
Start Up Rise Time	• 10 ms max
Hold Up Time	• 16/75 ms min at 115/230 VAC
Line Regulation	• $\pm$ 0.5%
Load Regulation	• $\pm$ 1% single output models; $\pm$ 3% V1, $\pm$ 5% V2 & V3 ECM40/60 multi-output models. $\pm$ 1% V1 & V2, $\pm$ 5% V3 & V4 ECM100
Cross Regulation	• 2% on ECM40/60 only
Over/Undershoot	• None at turn on/off
Transient Response	• 4% max. deviation, recovery to within 1% in 500 $\mu$ s for a 25% load change
Ripple & Noise	• 1% pk-pk, 20 MHz bandwidth
Overvoltage Protection	• 115-135% Vnom, recycle input to reset
Overload Protection	• 110-150% on primary power limit, auto recovery
Short Circuit Protection	• Trip and restart (hiccup mode)
Temperature Coefficient	• 0.05%/ $^{\circ}$ C
Peak Load	• 120% for 100 ms ECM40/60 (see note 3)

## Features

- Compact Size
- IT, Medical & SEMI F47 Approvals
- Convection-cooled
- Class I and II Construction
- DC Input Version Available (DCM Series)
- PoE Isolation Version Available (POE Series)
- ECM40/60: 4 x 2in open frame
- ECM100: 4.5 x 2.5in open frame

## General

Efficiency	• 80-85% depending on model
Isolation	• 4000 VAC Input to Output 1500 VAC Input to Ground 500 VAC Output to Ground
Switching Frequency	• 70 kHz typical
Power Density	• 40 W: 4.2 W/In <sup>3</sup> 60 W: 6.3 W/In <sup>3</sup> 100 W: 7.4 W/In <sup>3</sup>
MTBF	• 600 kHrs to MIL-HDBK-217F at 25 $^{\circ}$ C, GB

## Environmental

Operating Temperature	• 0 $^{\circ}$ C to +70 $^{\circ}$ C. Refer to derating curves for specific operating limitations.
Cooling	• Convection & fan-cooled ratings (see derating curves)
Operating Humidity	• 95% RH, non-condensing
Storage Temperature	• -40 $^{\circ}$ C to +85 $^{\circ}$ C
Operating Altitude	• 3000 m
Shock	• 30 g pk, half sine, 6 axes
Vibration	• 2 g rms, 5 Hz to 500 Hz, 3 axes

## EMC & Safety

Emissions	• EN60601-1-2, EN61204-3, FCC 20780, EN55022 & EN55011, level B conducted EN55022 Level A radiated
Harmonic Currents	• EN61000-3-2, class A
Voltage Flicker	• EN61000-3-3
ESD Immunity	• EN61000-4-2, level 3 Perf Criteria A
Radiated Immunity	• EN61000-4-3, 10 V/m Perf Criteria A
EFT/Burst	• EN61000-4-4, level 3 Perf Criteria A
Surge	• EN61000-4-5, level 3 Perf Criteria A
Conducted Immunity	• EN61000-4-6, 10 V Perf Criteria A
Dips & Interruptions	• EN61000-4-11, 30% 10 ms, 60% 100 ms, 100% 5000 ms, Perf Criteria A, B, B EN60601-1, 30% 500 ms, 60% 100 ms, 100% 10 ms, 100% 5000 ms, Perf Criteria A, A (with 50% load), A, B
Safety Approvals	• EN60950-1, UL60950-1, CSA 22.2 601.1, EN60601-1, UL60601-1 ECM40 & ECM60: SEMI F47

Output Power	Output 1		Output 2		Output 3		Model Number <sup>(2)</sup>
	Voltage	Current Min/Max <sup>(3)</sup>	Voltage	Current Min/Max	Voltage	Current Min/Max	
40 W	5.0 V	0.0 A/8.0 A					ECM40US05†^
	7.0 V	0.0 A/5.7 A					ECM40US07†
	9.0 V	0.0 A/4.4 A					ECM40US09†^
	12.0 V	0.0 A/3.5 A					ECM40US12†^
	15.0 V	0.0 A/2.7 A					ECM40US15†^
	18.0 V	0.0 A/2.2 A					ECM40US18†
	24.0 V	0.0 A/1.7 A					ECM40US24†^
	33.0 V	0.0 A/1.2 A					ECM40US33†
	48.0 V	0.0 A/0.9 A					ECM40US48†^
	+5.0 V	0.5 A/6.0 A	+12.0 V	0.1 A/2.0 A			ECM40UD21†
	+5.0 V	0.5 A/6.0 A	+15.0 V	0.1 A/1.5 A			ECM40UD22
	+5.0 V	0.5 A/6.0 A	+12.0 V	0.1 A/2.0 A	-12.0 V	0.0 A/0.5 A	ECM40UT31†^
	+5.0 V	0.5 A/6.0 A	+24.0 V	0.1 A/1.0 A	-12.0 V	0.0 A/0.5 A	ECM40UT32†
	+5.0 V	0.5 A/6.0 A	+15.0 V	0.1 A/1.5 A	-15.0 V	0.0 A/0.5 A	ECM40UT33†^
	+3.3 V	0.5 A/6.0 A	+5.0 V	0.1 A/1.5 A	+12.0 V	0.0 A/0.5 A	ECM40UT34†^
+5.0 V	0.5 A/6.0 A	+3.3 V	0.1 A/1.5 A	+12.0 V	0.0 A/0.5 A	ECM40UT35†	

### Notes

- V2 will track a change in V1 by the same percentage change in voltage as V1 is trimmed.
- To receive unit with cover fitted, add suffix '-C' to model number. For Class I operation only.
- A 120% peak load can be taken for up to 100 ms with a 25% duty cycle. Average load not to exceed 40 W.

### Mechanical Details

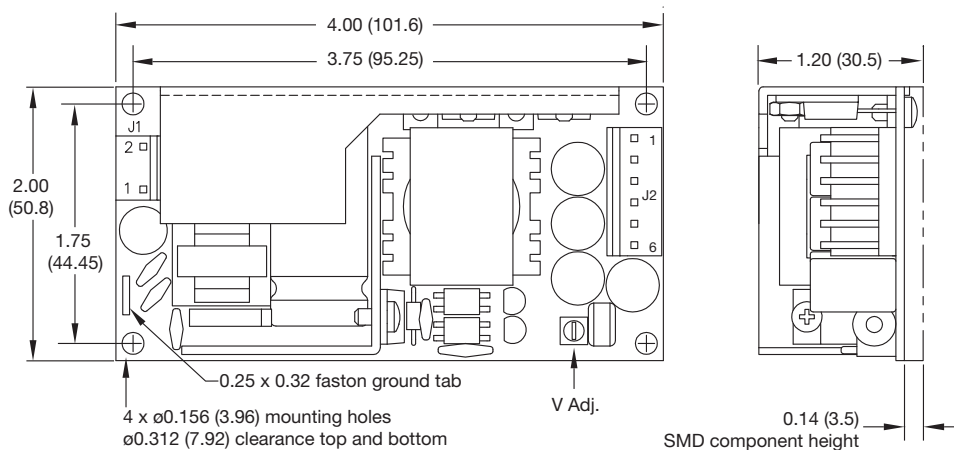

Input Connector J1	
Pin 1	Line
Pin 2	Neutral

J1 mates with Molex housing 43061-0003 & Molex series 5194 crimp terminals. Ground tab (0.25 faston) standard.

Output Connector J2		
Pin	Single	Multi
1	V1	+V1
2	V1	+V1
3	RTN	RTN
4	RTN	RTN
5	NC	V3
6	NC	+V2

J2 mates with Molex housing 43061-0006 & Molex series 5194 crimp terminals.

### Notes

- All dimensions in inches (mm). Tolerance .xx = ±0.02 (0.50); .xxx = ±0.01 (0.25)
- Weight: approx. 0.33 lbs (150 g)
- Cable harness with 300 mm wire available. For single output models, order part number ECM40/60S LOOM†. For multi-output models, order part number ECM40/60DT LOOM†^.
- Mating connector kit available. Order part number ECM40/60 CONKIT†.
- Covers available. Order part number ECM40/60 COVER†^.

### Derating Curves

#### All ECM40 models convection-cooled

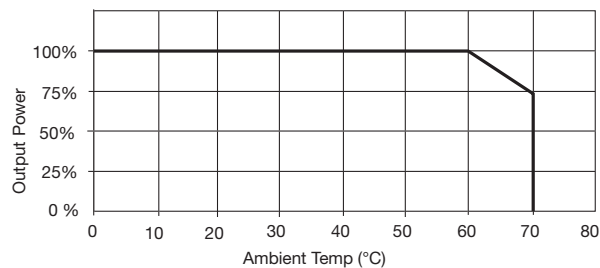

#### All ECM40 models with 5 CFM

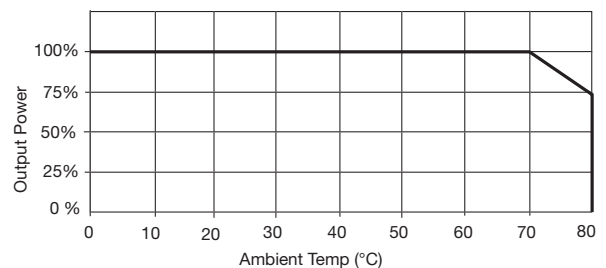

Note: Derate by 10% if cover is fitted

Consult longform datasheet for installation information regarding optimum thermal ratings in convection-cooled applications.

## Models and Ratings

Output Power	Output 1		Output 2		Output 3		Model Number <sup>(2)</sup>
	Voltage	Current Min/Max <sup>(3)</sup>	Voltage	Current Min/Max	Voltage	Current Min/Max	
60 W	5.0 V	0.0 A/12.00 A					ECM60US05†^A
	7.0 V	0.0 A/8.60 A					ECM60US07
	9.0 V	0.0 A/6.70 A					ECM60US09^A
	12.0 V	0.0 A/5.00 A					ECM60US12†^A
	15.0 V	0.0 A/4.00 A					ECM60US15†^A
	18.0 V	0.0 A/3.30 A					ECM60US18†
	20.0 V	0.0 A/3.00 A					ECM60US20
	24.0 V	0.0 A/2.50 A					ECM60US24†^A
	28.0 V	0.0 A/2.14 A					ECM60US28
	33.0 V	0.0 A/1.80 A					ECM60US33
	48.0 V	0.0 A/1.25 A					ECM60US48†^A
	+5.0 V	0.5 A/8.00 A	+12.0 V	0.1 A/3.0 A			ECM60UD21^A
	+5.0 V	0.5 A/8.00 A	+15.0 V	0.1 A/2.5 A			ECM60UD22
	+5.0 V	0.5 A/8.00 A	+12.0 V	0.1 A/3.0 A	-12.0 V	0.0 A/0.5 A	ECM60UT31†^A
	+5.0 V	0.5 A/8.00 A	+24.0 V	0.1 A/1.5 A	-12.0 V	0.0 A/0.5 A	ECM60UT32†
	+5.0 V	0.5 A/8.00 A	+15.0 V	0.1 A/2.5 A	-15.0 V	0.0 A/0.5 A	ECM60UT33†^A
	+3.3 V	0.5 A/8.00 A	+5.0 V	0.1 A/1.5 A	+12.0 V	0.0 A/0.5 A	ECM60UT34†^A
	+5.0 V	0.5 A/8.00 A	+3.3 V	0.1 A/1.5 A	+12.0 V	0.0 A/0.5 A	ECM60UT35†

### Notes

- V2 will track a change in V1 by the same percentage change in voltage as V1 is trimmed.
- To receive unit with cover fitted, add suffix '-C' to model number. For Class I operation only.
- A 120% peak load can be taken for up to 100 ms with a 25% duty cycle. Average load not to exceed 60 W.

## Mechanical Details

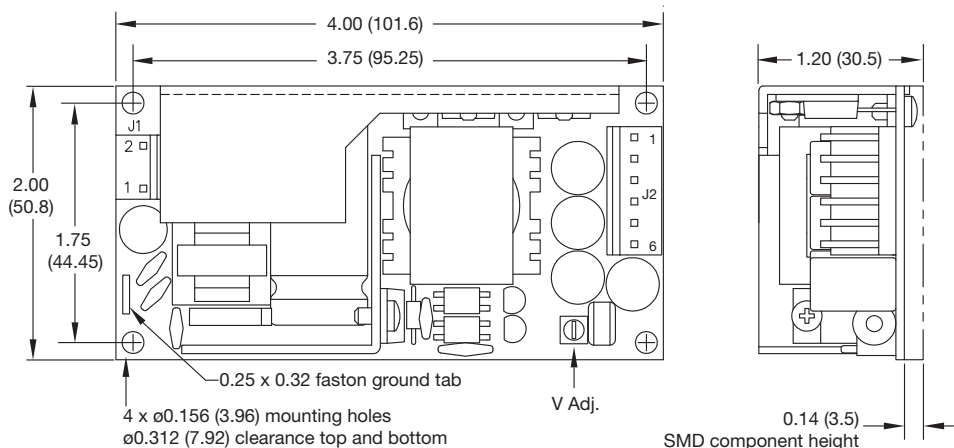

Input Connector J1	
Pin 1	Line
Pin 2	Neutral

J1 mates with Molex housing 43061-0003 & Molex series 5194 crimp terminals. Ground (0.25 faston) tab standard.

Output Connector J2		
Pin	Single	Multi
1	V1	+V1
2	V1	+V1
3	RTN	RTN
4	RTN	RTN
5	NC	V3
6	NC	+V2

J2 mates with Molex housing 43061-0006 & Molex series 5194 crimp terminals.

### Notes

- All dimensions in inches (mm). Tolerance .xx = ±0.02 (0.50); .xxx = ±0.01 (0.25)
- Weight: 0.33 lbs (150 g) approx.
- Cable harnesses with 300 mm wire available.  
For single output models, order part number ECM40/60S LOOM†.  
For multi-output models, order part number ECM40/60DT LOOM†.
- Mating connector kit available. Order part number ECM40/60 CONKIT†.
- Covers available. Order part number ECM40/60 COVER^†. Cover dimensions are 4.49 x 2.52 x 1.52 (114 x 64 x 38.5).
- Selected single output models available in a 3" x 5" footprint for OEM quantities. Contact sales for details.

## Derating Curves

### All ECM60 models convection-cooled

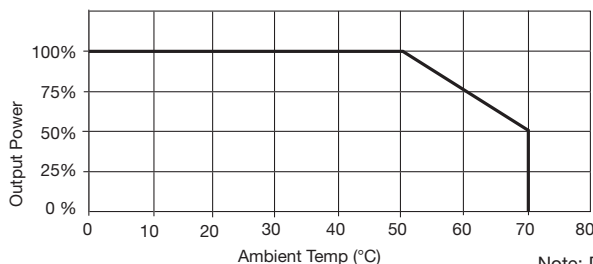

### All ECM60 models with 5 CFM

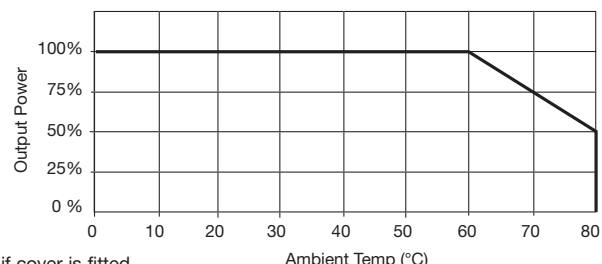

Note: Derate by 10% if cover is fitted

Consult longform datasheet for installation information regarding optimum thermal ratings in convection-cooled applications.

# Models and Ratings

## Single Output Models

Output Voltage	Output Current			Model Number <sup>(1)</sup>
	Minimum	Maximum	with 5 CFM Cooling	
3.3 V	0.0 A	15.0 A	20.0 A	ECM100US03†^
5.0 V	0.0 A	15.0 A	20.0 A	ECM100US05†^
7.0 V	0.0 A	11.4 A	14.3 A	ECM100US07
9.0 V	0.0 A	8.8 A	11.1 A	ECM100US09†^
12.0 V	0.0 A	7.5 A	8.3 A	ECM100US12†^
15.0 V	0.0 A	6.0 A	6.6 A	ECM100US15†^
18.0 V	0.0 A	5.0 A	5.5 A	ECM100US18
24.0 V	0.0 A	4.1 A	4.1 A	ECM100US24†^
28.0 V	0.0 A	3.6 A	3.6 A	ECM100US28
33.0 V	0.0 A	3.0 A	3.0 A	ECM100US33
48.0 V	0.0 A	2.1 A	2.1 A	ECM100US48†^

## Multi Output Models

Output Power		Output 1		Output 2		Output 3		Output 4		Model Number <sup>(1)</sup>
Convection Cooled	Forced Air 5 CFM	Voltage	Current Min/Max	Voltage	Current Min/Max	Voltage	Current Min/Max	Voltage	Current Min/Max	
80 W	100 W	+5.0 V	0.0 A/12.0 A	+12.0 V	0.0 A/3.0 A					ECM100UD21
80 W	100 W	+5.0 V	0.0 A/12.0 A	+15.0 V	0.0 A/3.0 A					ECM100UD22
75 W	100 W	+5.0 V	0.5 A/10.0 A	+12.0 V	0.0 A/3.0 A	-12.0 V	0.0 A/0.8 A			ECM100UT31†^
80 W	100 W	+5.0 V	0.5 A/10.0 A	+24.0 V	0.0 A/2.0 A	-12.0 V	0.0 A/0.8 A			ECM100UT32
80 W	100 W	+5.0 V	0.5 A/10.0 A	+15.0 V	0.0 A/3.0 A	-15.0 V	0.0 A/0.8 A			ECM100UT33†^
65 W	100 W	+3.3 V	0.5 A/10.0 A	+5.0 V	0.0 A/5.0 A	+12.0 V	0.0 A/0.8 A			ECM100UT34^
70 W	100 W	+5.0 V	0.5 A/10.0 A	+3.3 V	0.0 A/5.0 A	+12.0 V	0.0 A/0.8 A			ECM100UT35
80 W	100 W	+5.0 V	0.5 A/10.0 A	+12.0 V	0.0 A/3.0 A	-5.0 V	0.0 A/0.8 A			ECM100UT36
70 W	100 W	+5.0 V	0.5 A/10.0 A	+15.0 V	0.0 A/3.0 A	-5.0 V	0.0 A/0.8 A			ECM100UT37
65 W	100 W	+5.0 V	0.5 A/10.0 A	+3.3 V	0.1 A/5.0 A	+12.0 V	0.0 A/0.8 A	-12.0 V	0.0 A/0.5 A	ECM100UQ41†^
60 W	100 W	+3.3 V	0.5 A/10.0 A	+5.0 V	0.1 A/5.0 A	+12.0 V	0.0 A/0.8 A	-12.0 V	0.0 A/0.5 A	ECM100UQ42†^
80 W	100 W	+5.0 V	0.5 A/10.0 A	+24.0 V	0.1 A/2.0 A	+12.0 V	0.0 A/0.8 A	-12.0 V	0.0 A/0.5 A	ECM100UQ43†^
80 W	100 W	+5.0 V	0.5 A/10.0 A	+24.0 V	0.1 A/2.0 A	+15.0 V	0.0 A/0.8 A	-15.0 V	0.0 A/0.5 A	ECM100UQ44†^
80 W	100 W	+5.0 V	0.5 A/10.0 A	+12.0 V	0.1 A/3.0 A	-12.0 V	0.0 A/0.8 A	-5.0 V	0.0 A/0.5 A	ECM100UQ45^
80 W	100 W	+5.0 V	0.5 A/10.0 A	+15.0 V	0.1 A/3.0 A	-15.0 V	0.0 A/0.8 A	-5.0 V	0.0 A/0.5 A	ECM100UQ46

### Notes

- To receive unit with cover fitted, add suffix '-C' to model number.
- Output 3 available with opposite polarity for OEM quantities.

## Mechanical Details

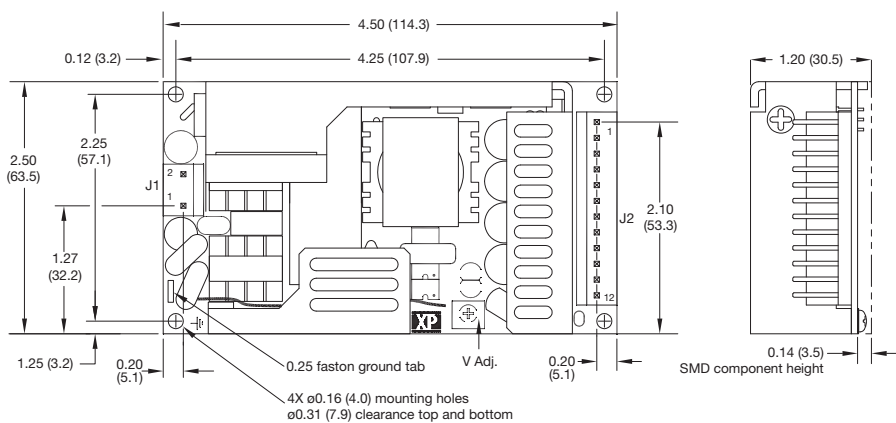

Cover dimensions are 4.98 x 3.01 x 1.54 (126.5 x 76.4 x 39.0)

### Notes

- All dimensions in inches (mm). Tolerance .xx = ±0.02 (0.50); .xxx = ±0.01 (0.25)
- Weight: 0.4 lbs (180 g) approx.
- Cable harness with 300 mm wire available. For single output models, order part number ECM100S LOOM†. For multi-outputs, p/n ECM100DT LOOM†.

Input Connector J1	
Pin 1	Line
Pin 2	Neutral

J1 mates with Molex housing 43061-0003 and Molex series 5194 crimp terminals. Ground (0.25 faston) tab standard.

Output Connector J2		
Pin	Single	Multi
1	V1	+V1
2	V1	+V1
3	V1	+V1
4	V1	+V1
5	V1 RTN	RTN
6	V1 RTN	RTN
7	V1 RTN	RTN
8	V1 RTN	RTN
9	NOT USED	+V2
10	NOT USED	+V2
11	NOT USED	±V3
12	NOT USED	-V4

J2 mates with Molex housing 43061-0012 and Molex series 5194 crimp terminals.

## Derating Curves

### All ECM100 single output models convection-cooled

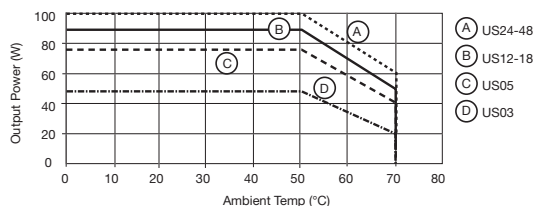

- Note:
- Derate by 10% if cover is fitted.
  - For multi output convection-cooled operation above +50 °C derate linearly to 50% at +70 °C.

### All ECM100 models with 5 CFM

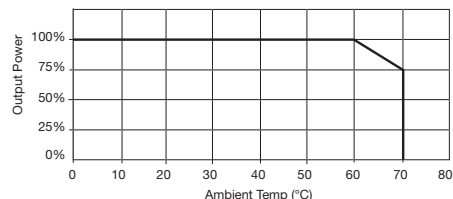

Consult longform datasheet for installation information regarding optimum thermal ratings in convection-cooled applications.