

# DCW100R SERIES

Rail DC/ DC Converters Single Output: 50 ~ 100 Watts



## General Specifications

<b>Input Voltage</b>	<b>24VDC</b> ( 14.4 ~ 34 ) <b>36VDC</b> ( 22 ~ 51 ) <b>48VDC</b> ( 29 ~ 67 ) <b>72VDC</b> ( 43 ~ 101 ) <b>96VDC</b> ( 58 ~ 135 ) <b>110VDC</b> ( 66 ~ 154 )
	• Other voltages on request
<b>Input Protection</b>	Reverse polarity protection. Inrush current limiting Lower voltage than specified will not damage unit
<b>Isolation</b>	Input - Output 3000vdc Input – Chassis 1500vdc Output – Chassis 1500vdc
<b>Efficiency</b>	Model dependent , typically 80-90%
<b>Output voltage</b>	See tables
<b>Output Power</b>	100 watts
<b>Voltage Adjust.</b>	Customer specified
<b>Immunity</b>	EN50155 & EN50121-3-2 EN61000-4-2 ESD EN61000-4-3 RF Immunity EN61000-4-4 Fast Transients EN50155 Surge & Voltage variations EN61000-4-6 Conducted Immunity
<b>EMI</b>	EN5022 Class B Conducted & Radiated
<b>Switching Freq.</b>	47kHz ±5kHz
<b>Regulation</b>	±1% Line / Load combined
<b>Dynamic Response</b>	Max ±5% deviation for 10% - 50% load step with 1msec recovery
<b>Ripple &amp; Noise</b>	Typically 1% pk-pk or 0.2% RMS of output voltage ( 20MHZ BW )
<b>Overload Protection</b>	Current limiting, with hiccup type short-circuit protection
<b>Overvoltage Protection</b>	Double regulator loop &Tranzorb across output
<b>Operating Temp.</b>	-25°C to +70°C cold plate temperature
<b>Cooling</b>	Conduction cooling / Convection cooling
<b>Environmental Protection</b>	Ruggedizing and Conformal coating of PCB.
<b>Shock &amp; Vibration</b>	IEC61373 Cat 1 A & B and Cat 2
<b>Humidity</b>	5-95% non-condensing, higher ration option
<b>MTBF</b>	>150,000 hrs

## Features

- Designed to rail standards EN50155 & EN50121
- Rugged design for on-board train applications
- Wide input voltage range
- Convection / Conduction cooled: No fans
- Fully isolated input – output 3000VDC
- Over voltage protection
- Overload and short circuit protection
- MTBF > 150,000hrs
- Specials input / output combinations on request.

## Description

The **DCW100R** series dc/dc converters are designed for use on Rail Rolling Stock and for many extremely harsh environments.

This rugged, industrial quality DC/DC converter uses a field proven topology to generate up to 100W continuous power, depending on the input/output configuration (i.e. efficiency).

It is a mature design with a track record in hundreds of applications. The series has large design headrooms and it is rated for operation over a -25 to +70°C temperature range.

It is cooled by conduction via baseplate to a heatsinking surface and by natural convection. These models are fully ruggedized and conformal coated for immunity to shock, vibration, humidity, moisture, dust and insects.

This chassis-mount design is optimized for low component count and high efficiency. The use of components with established reliability results in a high demonstrated MTBF.

Customized versions are also available.

Model	Input Options	Output Options		Power W
	V	V	A	
<b>DCW100R</b>	24V, 36V	12V	8A	100W
	48V, 72V	24V	4A	
	96V, 110V	48V	2A	
		110V	0.9A	

- Final part numbers will be factory allocated to reflect customer input & output requirements.
- Any output from 12-125V is possible.

<b>LED / Indicator</b>	Optional
<b>Alarm output</b>	Optional on some models
<b>Connector</b>	6 pole barrier-type terminal block with 3/8"spacing. ( optional cover )
<b>Dimensions</b>	87 x 50 x 155mm (F0 ) W x H x L ( includes terminal block & mounting flanges)
<b>Weight</b>	0.6kg

# DCW100R SERIES

Rail DC/DC Converters Single Output: 50 ~ 100 Watts

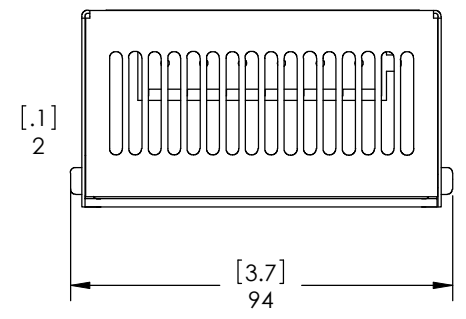
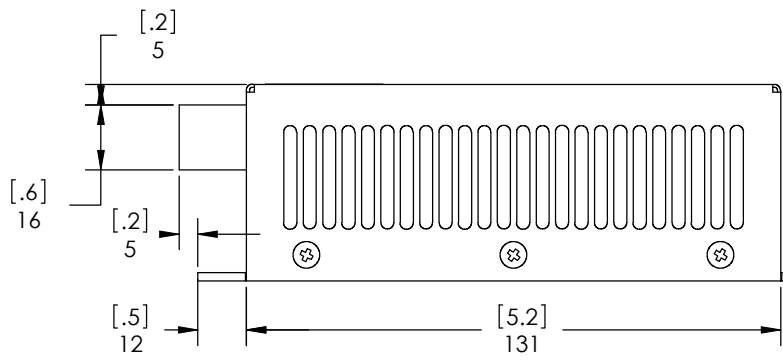
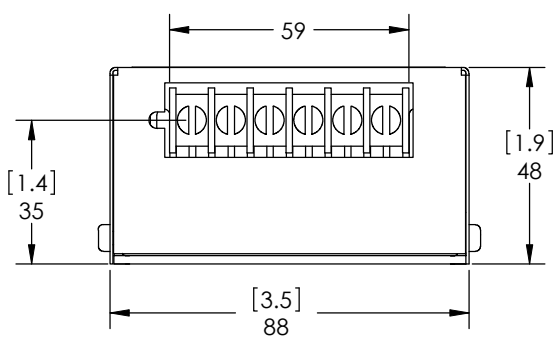
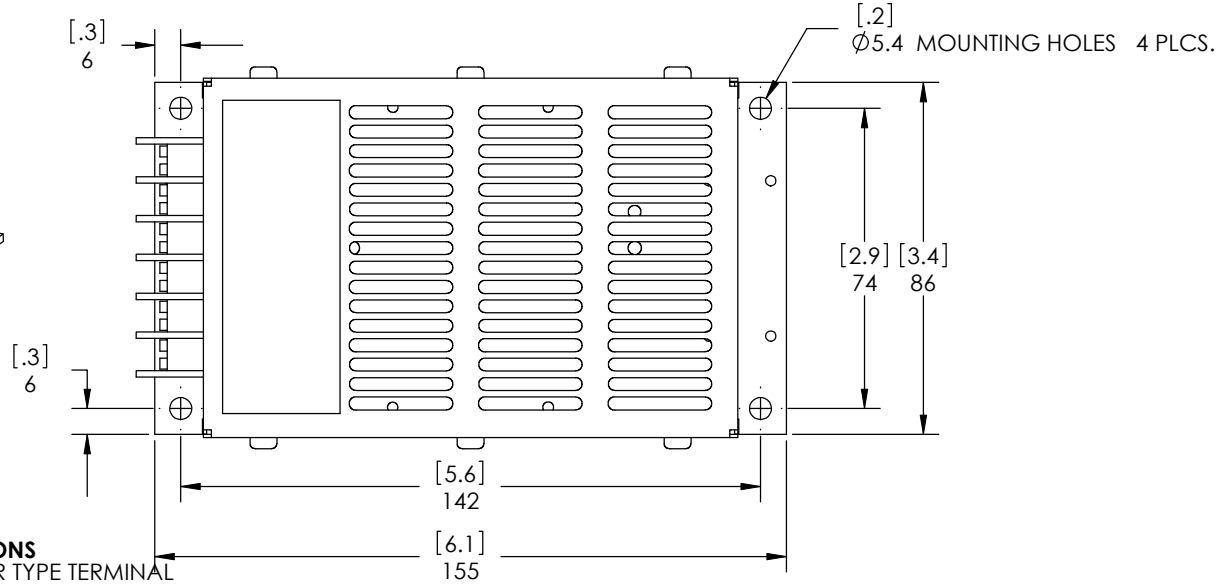
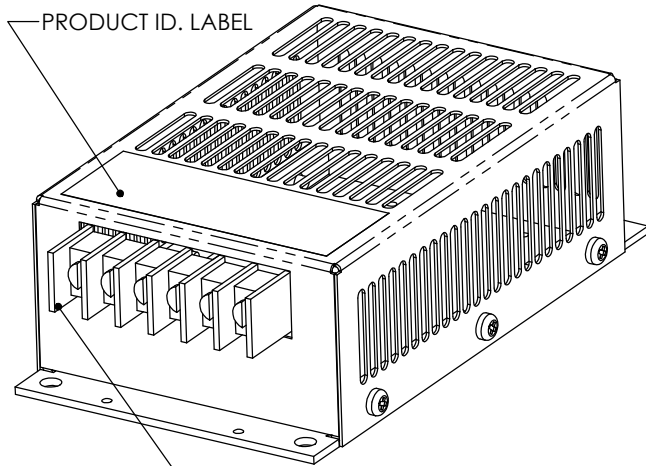

DIMENSIONS ARE IN MILLIMETERS  
[INCHES] TOLERANCES ON  
DECIMALS: XXX ± 0.2mm  
          XX ± 0.3mm  
ANGLES: ± 2°  
FRACTIONS: ± 0.4mm  
UNLESS OTHERWISE STATED

THIS DOCUMENT IS THE PROPERTY  
OF AMTEX ELECTRONICS LTD.  
ITS CONTENTS ARE PROPRIETARY AND  
MAY NEITHER BE COPIED, REPRODUCED  
NOR ITS CONTENTS DISCLOSED TO OTHERS  
WITHOUT PRIOR WRITTEN AGREEMENT  
FROM AMTEX ELECTRONICS LTD.

Title: OUTLINE DRAWING

Part of: F0 PACKAGE

