

CA-CX BATTERY CHARGERS

Battery Chargers 200 - 1000 Watts

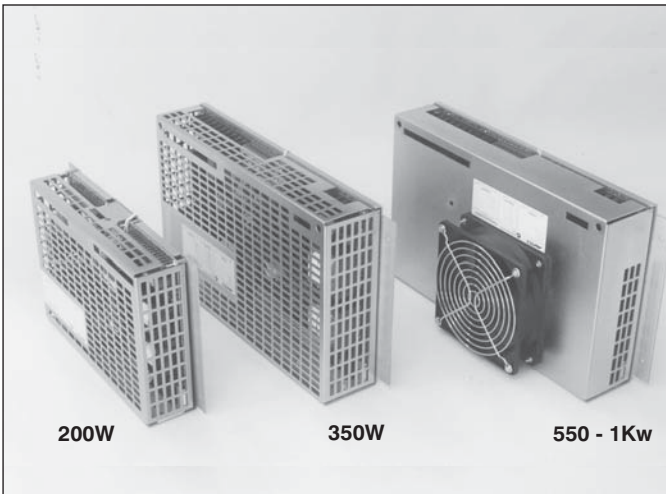

Features

- Switched mode design
- Output options: 12V, 24V, 36V, 48V, 60V & 108V
- Power levels from 200 to 750 watts
- Constant voltage/constant current operation
- Overvoltage and overload protection
- Power Fail and Battery Low alarm signals
- Temperature compensation charging
- EMC to EN55022 and EN61000
- N+1 redundancy operation
- CE marked to Low Voltage Directive
- AS3260 safety approval: NCS7346N
- EMC approved
- Battery low volt disconnect

The CX series rectifiers offer the most comprehensive range of battery chargers for use in "DC Standby Systems".

We have redesigned our already popular ZX Series to include a new range of features such as battery under voltage disconnect, temperature compensation charging and power share signal, making them the complete charger for powering critical DC loads.

We can easily customise units to meet specific application requirements, and can offer complete systems with batteries, distribution breakers, meters etc., for small or large projects.

19" Rack Mounting option, with and without meters



Specifications

INPUT VOLTAGE:	115/240 VAC standard, 400 VAC single phase - option 90 - 264 VAC with PFC - option DC input from 24V - 370DC - option								
FREQUENCY:	44 - 66Hz (400Hz optional)								
SWITCHING FREQUENCY:	CX200 - CX300 models: 44KHz, CX350 - CX750 models: 33KHz								
INPUT PROTECTION:	On board input fuse and inrush current limiting								
EFFICIENCY:	Model dependent, 86 - 95%								
RIPPLE & NOISE:	<0.1% rms, <1% pk - pk								
DYNAMIC REGULATION:	<1%, 1ms 10% load change								
LOAD REGULATION:	<1% for 10 - 100% load change								
LINE REGULATION:	<0.5%								
VOLTAGE ADJUSTMENT:	On-board trim pot allows fine tuning (±5%) of battery float voltage								
EMC EMISSIONS:	Conducted: EN55022 - B Radiated: EN55022 - A								
EMC IMMUNITY:	EN61000 - 4 - 2 level 3 ESD EN61000 - 4 - 5 level 3 Surge EN61000 - 4 - 4 Burst EN50140 level 3 Radiated								
ISOLATION:	Input - output 3750 VAC Input - chassis 2200 VDC Output - chassis 500 VDC								
SAFETY:	Designed to meet EN60950, CE market to LVD								
PROTECTION:	<ul style="list-style-type: none"> • Overload/short circuit protection • Overvoltage protection • Over temperature protection 								
MTBF:	150,000 hrs per MIL - STD 217E @ 20°C								
OPERATING TEMP:	0° to 40°C at rated power. Consult Amtex for derating from 40° to 70°C								
HUMIDITY:	0% to 90% non-condensing								
VIBRATION & SHOCK:	Operating: 5 - 50Hz 0.05mm pk - pk 50 - 100Hz 0.025mm pk - pk Non-operating: 100mm drop onto chassis face								
PARALLEL OPERATION:	Consult Amtex for details								
SERIES OPERATION:	Yes								
SIGNALS & ALARMS:	<ul style="list-style-type: none"> • Power Fail Alarm (voltage free contacts) • Battery Low Alarm (voltage free contacts) • Rectifier V out Test Point: Monitors Vout before diode 1A max rating 								
COOLING:	CX200 & CX350 convection cooled CX300, CX550 & CX750 internal fan cooling								
CONNECTIONS:	Screw terminals for input and output								
DIMENSIONS & WEIGHT:	<table border="0"> <tr> <td>CA200: 260 x 160 x 55mm</td> <td>1.5Kg.</td> </tr> <tr> <td>CA300: 260 x 160 x 82mm</td> <td>1.7Kg.</td> </tr> <tr> <td>CA350: 340 x 190 x 65mm</td> <td>2.5Kg.</td> </tr> <tr> <td>CA550-CA1k: 340 x 190 x 104mm</td> <td>3.0Kg.</td> </tr> </table>	CA200: 260 x 160 x 55mm	1.5Kg.	CA300: 260 x 160 x 82mm	1.7Kg.	CA350: 340 x 190 x 65mm	2.5Kg.	CA550-CA1k: 340 x 190 x 104mm	3.0Kg.
CA200: 260 x 160 x 55mm	1.5Kg.								
CA300: 260 x 160 x 82mm	1.7Kg.								
CA350: 340 x 190 x 65mm	2.5Kg.								
CA550-CA1k: 340 x 190 x 104mm	3.0Kg.								



CA-CX BATTERY CHARGERS

200 - 1000 Watts

Standard Series Battery Charging Table

Unit Output Code*	Battery Voltage				Unit Model (Watts)					
	Fail (1.75V/cell)	Nom (2V/cell)	Float (2V25/cell)	Boost (2V4/cell) (option)	200W	300W	350W	550W	750W	1Kw
					Maximum Charging Current (A)					
06	5.25	6	6.75	7.2	29.6	44.4	52.0	81.5	---	---
12	10.5	12	13.5	14.4	14.8	22.2	26.0	40.7	55.5	---
24	21.0	24	27.0	28.8	7.4	11.1	13.0	20.4	27.7	40.7
36	31.5	36	40.5	43.2	4.9	7.4	8.6	13.6	18.5	27.6
48	42.0	48	54.0	57.6	3.7	5.5	6.5	10.2	13.9	20.7
60	52.5	60	67.5	72.0	3.0	4.4	5.2	8.1	11.1	16.2
96	84.0	96	108.0	115.0	1.8	2.8	3.2	5.1	7.0	10.2
11	94.5	108	121.5	129.6	1.6	2.5	2.9	4.5	6.2	9.0
20	168.0	192	216.0	230.0	0.9	1.4	1.6	2.5	3.5	5.1
22	189.0	216	243.0	259.0	0.8	1.2	1.4	2.3	3.1	4.6

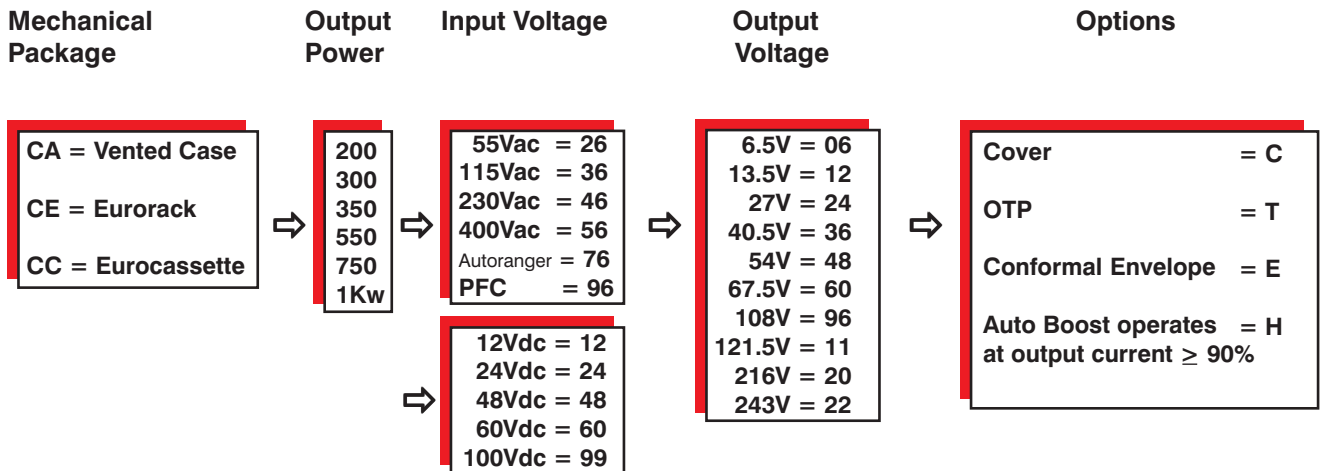

Model Number Example:

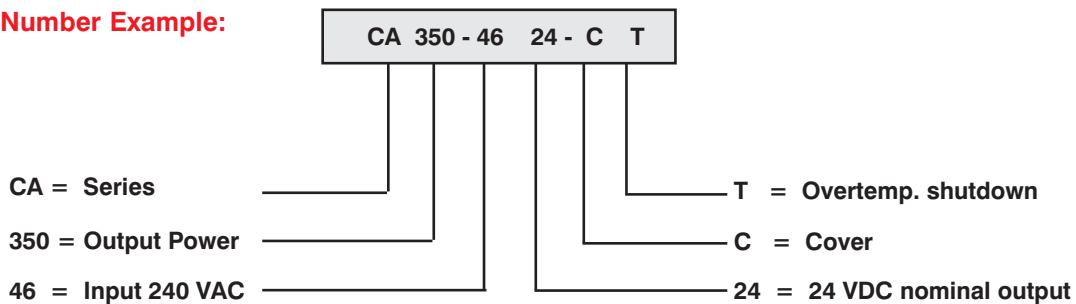

Note: Not all input - output combinations available.

CA-CX BATTERY CHARGERS

Battery Charging Using "CA" Series Rectifiers

The CA series rectifiers have been designed to operate in **constant current/constant voltage** mode for battery charging applications. These units will deliver a constant current when connected to a discharged battery until the float voltage is attained, the constant voltage mode of the unit will then maintain this level.

Example of 200W Unit Configured to charge a 24 cell (2V x 24 = 48V system) Lead Acid Battery:

The rectifier will charge at 5A until the constant voltage mode of the unit is achieved across the battery, (this is normally set to 2.25V/cell), in this case 54V. Thereafter the rectifier will maintain the 54V by way of its constant output voltage.

Fig. 1 Battery Back-up Block Diagram

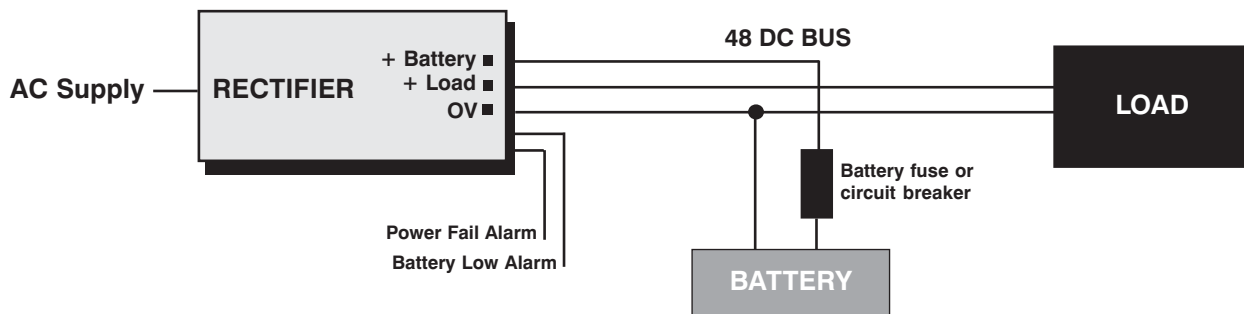

Rectifier Selection:

Selecting the correct rectifier power rating is important for the long term reliability of the system and battery, using the following equation as a guide.

$$I_R = I_L + I_B$$

I_R = rectifier output current, I_L = load current, I_B = battery charge current (10 - 15% of AH capacity of the battery)

Battery Selection:

Selecting the right battery is just as important for optimum system performance. Usually we start by deciding what battery **back-up** time is required. Once this is decided, then using the following battery selection guide and battery manufactures data, the correct AH capacity and type of battery can be selected.

Manufacturer/Reference		
Battery Capacity		Ah
Nominal Voltage		V
Float/Standby		V/cell
Boost/Cyclic		V/cell
Charging Current		A

Features:

The CX series rectifiers have been designed specifically for battery charging and standby DC systems and include the following features:

- Factory set 2.25V per cell float charge voltage. On board potentiometer allows for $\pm 5\%$ voltage adjustment
- Temperature charge compensation $-3\text{mV}/^\circ\text{C}/\text{cell}$
- Automatic boost voltage 2.4V per cell when output current is greater than 90% - option **H**
- Supply/Power Fail alarm, via voltage free relay contacts (Power Fail = $<190/95\text{V}$, Power Good = $>200/100\text{V}$)
- Battery under voltage disconnect to avoid deep discharge (maximum disconnect current: 30A)
- Battery Low alarm, via voltage free relay contacts (Battery Low = $<1.75\text{V}/\text{cell}$, Battery Good = $>2\text{V}/\text{cell}$)
- Battery fail relay operates approximately 20 seconds before under voltage disconnect
- Alarm relay contact rating: 1A @ 24 VDC, 0.5A @ 120 VAC
- Output isolation (OR) diode for zero bleed on battery in UVD
- Power Share for N+1 redundancy operation

CA-CX BATTERY CHARGERS

CA 200, CA300 (Fan not fitted to CA 200W)

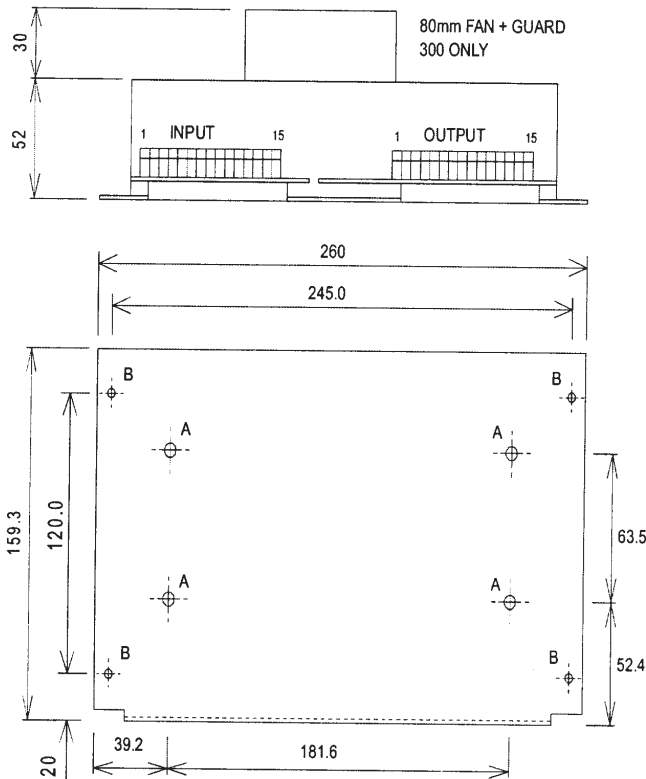

Connections:

Input 5mm pitch	Signals/Output 5mm pitch
1: Earth	1: TEST
2: N/C	2: ROF
3: Neutral	3: Power share
4: N/C	4: Power fail COM
5: Line	5: Power fail N/C
6: N/C	6: Power fail N/O
7: 115V link	7: Batt fail COM
8: 115V link	8: Batt fail N/C
9: N/C	9: Batt fail N/O
10: N/C	10: 0V
11: N/C	11: 0V
12: N/C	12: +LOAD
13: N/C	13: +LOAD
14: N/C	14: +BATTERY
15: N/C	15: +BATTERY

CA 350, CA550, CA750, CA1Kw (Fan not fitted to CA350W)

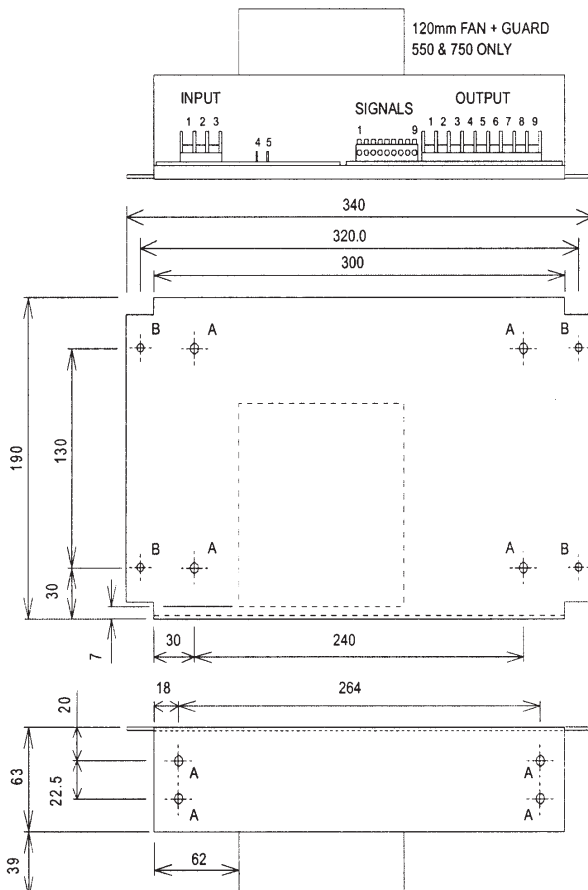

Connections:

Input 9.5mm pitch	Output 9.5mm pitch
1: Earth	1: 0V
2: Neutral	2: 0V
3: Line	3: 0V
4: 115V link	4: +LOAD
5: 115V link	5: +LOAD
	6: +LOAD
	7: +BATTERY
	8: +BATTERY
	9: +BATTERY

Signals

- 1: TEST
- 2: Remote on-off
- 3: Power share
- 4: Power fail COM
- 5: Power fail N/C
- 6: Power fail N/O
- 7: Batt fail COM
- 8: Batt fail N/C
- 9: Batt fail N/O