

LS Series

TDK-Lambda

Compact AC/DC Switching Power Supply



**Economical and Ecological
Single Output Power Supply**

Affordable AC/DC Switching Power Supply with High Quality Standard

Compact Size

LS Series are smaller than current models in which can give more flexibility in design. This compact design is ideal for application including indoor display, self service kiosk, and vending machines.

Wide Operating Temperatures

LS series are designed to operate reliably between -25°C to 50°C at 100% load and up to 70°C at derated load. This feature is the best solution for equipment to run in extreme environments.

*Refer to each model specification for derating

Economical and Environmental Friendly

High efficiency power output will reduce the amount of wasted energy. Strict evaluation of components used will also reduce defect. Therefore, user's overall running cost can be minimized.

Low and High Voltage Full Line Up

LS series cover most of the output voltage to cater wide range of applications. The available 36V is suitable for applications like printer head or LED display panel.

A Power Supply that Protect Your Equipments

LS series are not only designed to meet the harmonic current standard (IEC61000-3-2,-3), but also to pass this standard with enough margin so that equipments will be well protected against overheating and malfunction. In addition to conformance to the international standards, LS series have less than 1mA leakage current and ability to withstand 300VAC surge for 5 seconds for better safety and protection.

LS SERIES

Single Output 25W to 150W

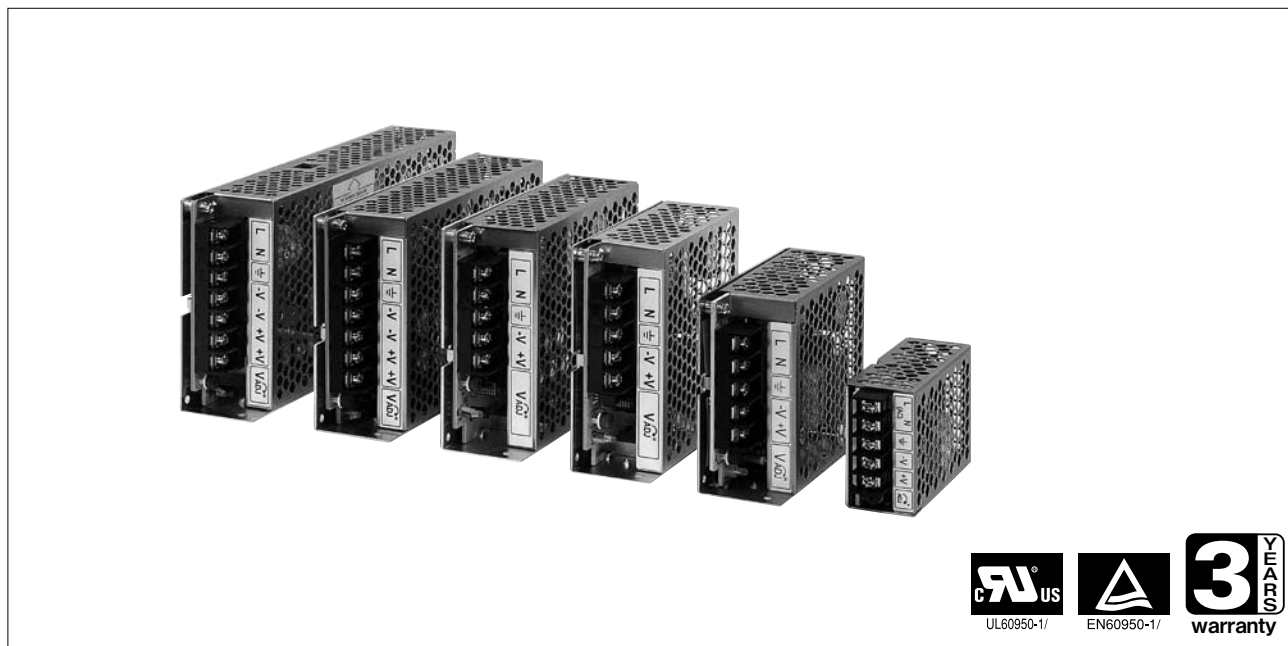

Features

- Compact Size
- Economical and Environmental Friendly
- Wide Operating Temperatures up to 70°C
- Low and High Voltage Full Line Up

Model naming method

LS 25 - 5

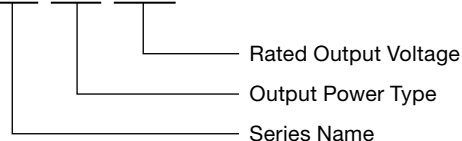

Applications

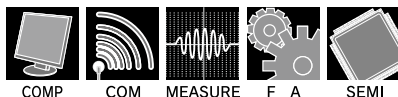

Product line up

Output Voltage	25W		35W		50W		75W		100W		150W	
	Output Current	Model	Output Current	Model	Output Current	Model	Output Current	Model	Output Current	Model	Output Current	Model
3.3V	6A	LS25-3.3	7A	LS35-3.3	10A	LS50-3.3	15A	LS75-3.3	20A	LS100-3.3	30A	LS150-3.3
5V	5A	LS25-5	7A	LS35-5	10A	LS50-5	12A	LS75-5	16A	LS100-5	26A	LS150-5
12V	2.1A	LS25-12	3A	LS35-12	4.2A	LS50-12	6A	LS75-12	8.5A	LS100-12	12.5A	LS150-12
15V	1.7A	LS25-15	2.4A	LS35-15	3.4A	LS50-15	5A	LS75-15	7A	LS100-15	10A	LS150-15
24V	1.1A	LS25-24	1.5A	LS35-24	2.2A	LS50-24	3.2A	LS75-24	4.5A	LS100-24	6.5A	LS150-24
36V	0.75A	LS25-36	1A	LS35-36	1.4A	LS50-36	2.1A	LS75-36	3A	LS100-36	4.3A	LS150-36
48V	0.57A	LS25-48	0.8A	LS35-48	1.1A	LS50-48	1.6A	LS75-48	2.3A	LS100-48	3.3A	LS150-48

LS25 Specifications

ITEMS/UNITS		MODEL	LS25-3.3	LS25-5	LS25-12	LS25-15	LS25-24	LS25-36	LS25-48
Input	Voltage Range	(*2) V	AC88 to 264 or 125 to DC373 (Withstand AC300 Surge for 5 seconds)						
	Frequency	(*2) Hz	47-63						
	Efficiency(230VAC)(typ)	(*1) %	75	79	83		84		85
	Current(115/230VAC)(typ)	(*1) A	0.7 / 0.4						
	Inrush Current(typ)	(*3) A	30A at 230VAC, Ta=25°C (Cold Start)						
	Leakage Current	(*10) mA	< 1mA at 230VAC						
Output	Nominal Voltage	VDC	3.3	5	12	15	24	36	48
	Maximum Current	A	6	5	2.1	1.7	1.1	0.75	0.57
	Maximum Power	W	19.8	25	25.2	25.5	26.4	27	27.36
	Maximum Line Regulation	(*5)(*6) mV	20		48	60	96	144	192
	Maximum Load Regulation	(*5)(*7) mV	40		96	120	192	288	384
	Temperature Coefficient		Less than 0.02%/°C						
	Maximum Ripple & Noise	(*1)(*4) mVp-p	80		120			150	200
	Hold-up Time(115/230VAC)(typ)	(*1) ms	14 / 80						
	Voltage Adjustable Range	VDC	2.85 to 3.6	4.5 to 5.5	10.8 to 13.2	13.5 to 16.5	22 to 27.6	32 to 40	42 to 54
Function	Over Current Protection	(*8) A	> 110% rated output current						
	Over Voltage Protection	(*9) VDC	> 120% nominal output voltage						
	Series Operation		Possible						
Environment	Operating Temperature	(*11) °C	- 25 to + 70 (Refer to Output Derating Curve)						
	Storage Temperature	°C	- 40 to +85						
	Operating Humidity	%RH	20 to 90 (No dewdrop)						
	Storage Humidity	%RH	10 to 95 (No dewdrop)						
	Vibration		At no operating, 10 - 55Hz (sweep for 1min) 19.6m/s ² Constant, X, Y, Z 1hour each.						
	Shock(In package)		Less than 196.1m/s ²						
	Cooling		Convection cooling						
	Isolation	Withstand Voltage		Input - Output : 3.0kVAC (20mA), Input - FG : 1.5kVAC (20mA) Output - FG : 500VAC (100mA) for 1min.					
Isolation Resistance			Input - FG, Input - Output and Output - FG: More than 100MΩ (500VDC) at 25°C and 70%RH						
Standards	Safety Standards		Approved by UL60950-1, EN60950-1, IEC60950-1						
	PFHC		Built to meet IEC61000-3-2, -3						
	EMI		Built to meet EN55011/EN55022-B, FCC-B						
	Immunity		Built to meet EN61000-4-2 (Level 2,3), -3 (Level 3), -4 (Level 3), -5 (Level 3), -6 (Level 3), -8 (Level 4), -11						
Mechanical	Weight(typ)	g	170						
	Size (W×H×D)	mm	79 x 51 x 28 (Refer to Outline Drawing)						

(*1) At Maximum Output Power, nominal input voltage, Ta = 25°C.

(*2) For cases where conformance to various safety specs (UL, CSA, EN) are required, to be described as 100 - 240VAC, 50 / 60Hz on name plate.

(*3) Not applicable for the in-rush current to Noise Filter for less than 0.2mS.

(*4) Ripple & noise are measured at 20MHz by using a 300mm twisted pair of load wires terminated with a 0.1uF film capacitor and a 47uF electrolytic capacitor.

(*5) Measure line & load regulation at output terminal M3 tapped point.

(*6) 88 - 264VAC, constant load.

(*7) No load - Full load (Maximum power), constant input voltage.

(*8) Current limit with automatic recovery.

Avoid to operate at overload or dead short for more than 30 seconds.

(*9) Over voltage clamp by zener diode, hiccup mode.

(*10) Measured by each measuring method of UL and EN (at 60Hz), Ta = 25°C.

(*11) Refer to Output Derating Curve (PA580-01-02_) for details of output derating versus ambient temperature.

(*12) All parameters NOT specifically mentioned are measured at 230VAC input, rated load and Ta = 25°C.

LS25 Outline Drawing

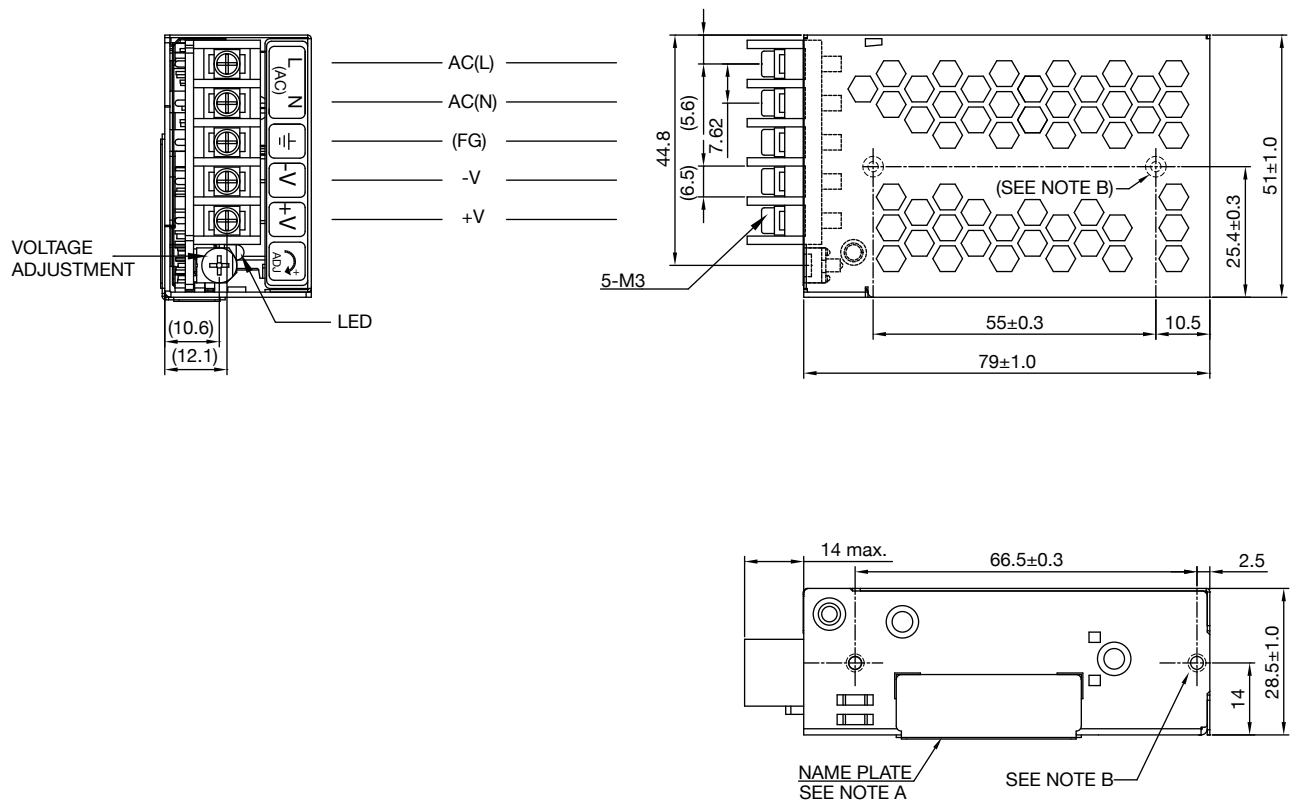

NOTES

- A. MODEL NAME, INPUT VOLTAGE RANGE, NOMINAL OUTPUT VOLTAGE, MAXIMUM OUTPUT CURRENT & COUNTRY OF MANUFACTURE ARE SHOWN IN ACCORDANCE WITH THE SPECIFICATION.
- B. M3 TAPPED, EMBOSSED & COUNTERSUNK HOLES (4) FOR CUSTOMER CHASSIS MOUNTING. SCREWS MUST NOT PROTRUDE INTO POWER SUPPLY BY MORE THAN 4mm.
- C. UNLESS OTHERWISE SPECIFIED, DIMENSION TOLERANCE = ±0.3mm.

LS25 Output Derating

***COOLING : CONVECTION COOLING**

Ta (°C)	LOAD (%)	STANDARD MOUNTING
-25 to +40	100	
50	86.7(3.3V), 100(OTHERS)	
70	60	

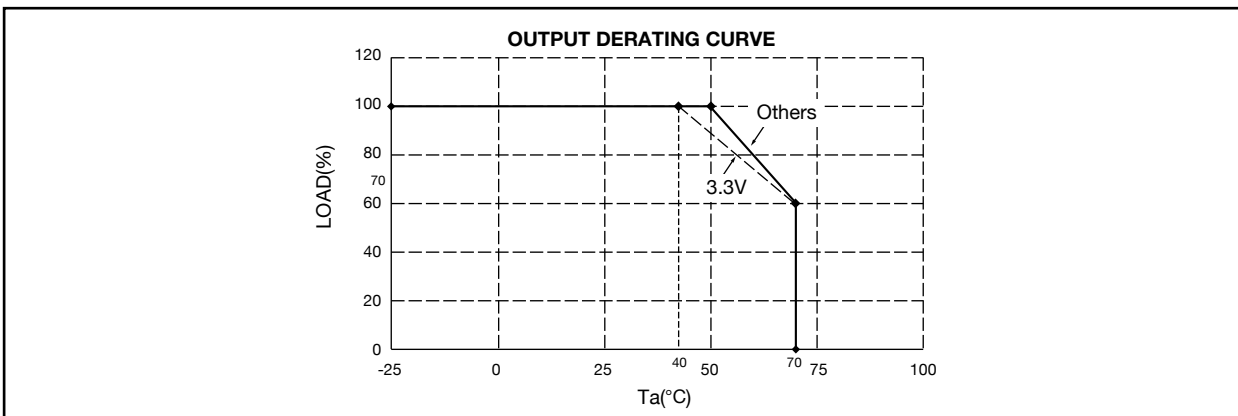

LS35 Specifications

ITEMS/UNITS		MODEL	LS35-3.3	LS35-5	LS35-12	LS35-15	LS35-24	LS35-36	LS35-48
Input	Voltage Range	(*2) V	AC88 to 264 or 125 to DC373 (Withstand AC300 Surge for 5 seconds)						
	Frequency	(*2) Hz	47-63						
	Efficiency(230VAC)(typ)	(*1) %	75	78	82	83	84		
	Current(115/230VAC)(typ)	(*1) A	0.8 / 0.55						
	Inrush Current(typ)	(*3) A	40A at 230VAC, Ta=25°C (Cold Start)						
	Leakage Current	(*10) mA	< 1mA at 230VAC						
Output	Nominal Voltage	VDC	3.3	5	12	15	24	36	48
	Maximum Current	A	7		3	2.4	1.5	1	0.8
	Maximum Power	W	23.1	35	36				38.4
	Maximum Line Regulation	(*5)(*6) mV	20		48	60	96	144	192
	Maximum Load Regulation	(*5)(*7) mV	40		96	120	192	288	384
	Temperature Coefficient		Less than 0.02%/°C						
	Maximum Ripple & Noise	(*1)(*4) mVp-p	80		120			150	200
	Hold-up Time(115/230VAC)(typ)	(*1) ms	15 / 80						
	Voltage Adjustable Range	VDC	2.85 to 3.6	4.5 to 5.5	10.8 to 13.2	13.5 to 16.5	22 to 27.6	32 to 40	42 to 54
Function	Over Current Protection	(*8) A	> 110% rated output current						
	Over Voltage Protection	(*9) VDC	3.8 to 4.45	5.75 to 6.75	13.8 to 16.2	17.25 to 20.25	29 to 32.4	41.4 to 48.6	55.2 to 64.8
	Series Operation		Possible						
Environment	Operating Temperature	(*11) °C	- 25 to + 70 (Refer to Output Derating Curve)						
	Storage Temperature	°C	- 40 to +85						
	Operating Humidity	%RH	20 to 90 (No dewdrop)						
	Storage Humidity	%RH	10 to 95 (No dewdrop)						
	Vibration		At no operating, 10 - 55Hz (sweep for 1min) 19.6m/s ² Constant, X, Y, Z 1hour each.						
	Shock(In package)		Less than 196.1m/s ²						
	Cooling		Convection cooling						
Isolation	Withstand Voltage		Input - Output : 3.0kVAC (20mA), Input - FG : 1.5kVAC (20mA) Output - FG : 500VAC (100mA) for 1min.						
	Isolation Resistance		Input - FG, Input - Output and Output - FG: More than 100MΩ (500VDC) at 25°C and 70%RH						
Standards	Safety Standards		Approved by UL60950-1, EN60950-1, IEC60950-1						
	PFHC		Built to meet IEC61000-3-2, -3						
	EMI		Built to meet EN55011/EN55022-B, FCC-B						
	Immunity		Built to meet EN61000-4-2 (Level 2,3), -3 (Level 3), -4 (Level 3), -5 (Level 4), -6 (Level 3), -8 (Level 4), -11						
Mechanical	Weight(typ)	g	270						
	Size (W×H×D)	mm	99 x 82 x 36 (Refer to Outline Drawing)						

(*1) At Maximum Output Power, nominal input voltage, Ta = 25°C.

(*2) For cases where conformance to various safety specs (UL, CSA, EN) are required, to be described as 100 - 240VAC, 50 / 60Hz on name plate.

(*3) Not applicable for the in-rush current to Noise Filter for less than 0.2mS.

(*4) Ripple & noise are measured at 20MHz by using a 300mm twisted pair of load wires terminated with a 0.1uF film capacitor and a 47uF electrolytic capacitor.

(*5) Measure line & load regulation at output terminal M3.5 tapped point.

(*6) 88 - 264VAC, constant load.

(*7) No load - Full load (Maximum power), constant input voltage.

(*8) Current limit with automatic recovery.

Avoid to operate at overload or dead short for more than 30 seconds.

(*9) OVP circuit will shutdown output, manual reset (Re-power on).

(*10) Measured by each measuring method of UL and EN (at 60Hz), Ta = 25°C.

(*11) Refer to Output Derating Curve (PA581-01-02_) for details of output derating versus ambient temperature.

(*12) All parameters NOT specifically mentioned are measured at 230VAC input, rated load and Ta = 25°C.

LS35 Outline Drawing

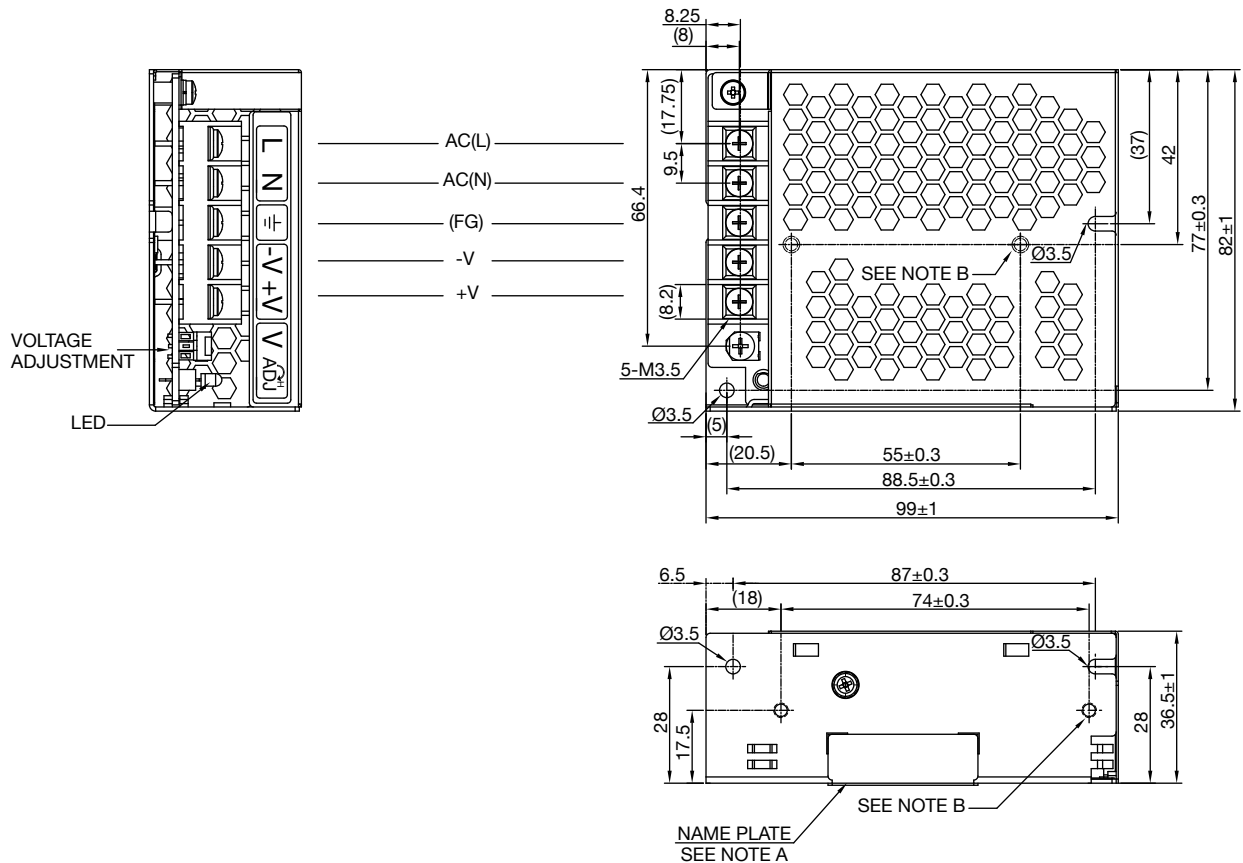

NOTES

- A. MODEL NAME, INPUT VOLTAGE RANGE, NOMINAL OUTPUT VOLTAGE, MAXIMUM OUTPUT CURRENT & COUNTRY OF MANUFACTURE ARE SHOWN IN ACCORDANCE WITH THE SPECIFICATION.
- B. M3 TAPPED, EMBOSSED & COUNTERSUNK HOLES (4) FOR CUSTOMER CHASSIS MOUNTING. SCREWS MUST NOT PROTRUDE INTO POWER SUPPLY BY MORE THAN 5mm.
- C. UNLESS OTHERWISE SPECIFIED, DIMENSION TOLERANCE = ±0.3mm.

LS35 Output Derating

***COOLING : CONVECTION COOLING**

Ta (°C)	LOAD (%)	STANDARD MOUNTING
-25 to +50	100	
70	50	

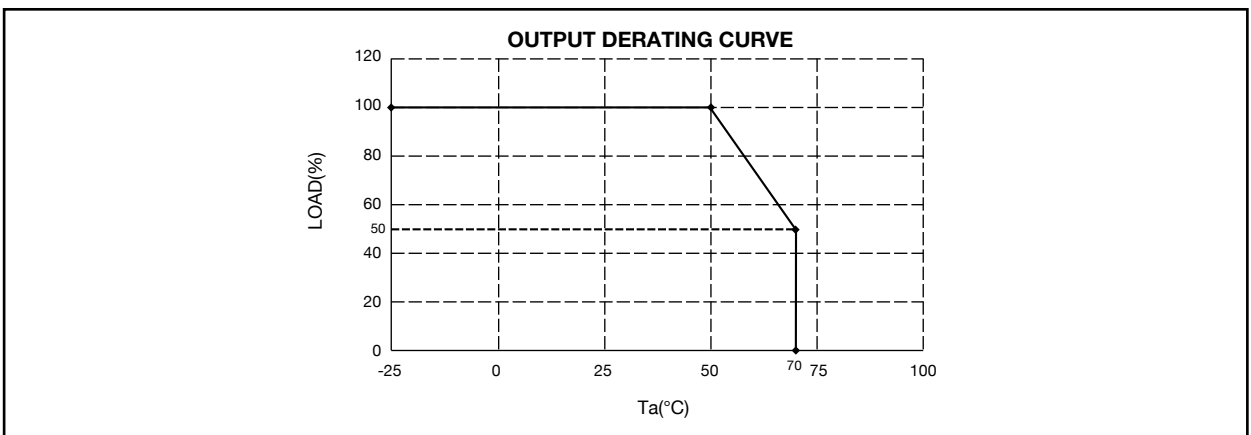

LS50 Specifications

ITEMS/UNITS		MODEL	LS50-3.3	LS50-5	LS50-12	LS50-15	LS50-24	LS50-36	LS50-48
Input	Voltage Range (*2)	V	AC88-264 or DC125-373 (Withstand AC300 Surge for 5 seconds)						
	Frequency	Hz	47-63						
	Efficiency (230VAC)(Typ) (*1)	%	75	80	84	85	86		
	Current (115/230VAC)(Typ) (*1)	A	1.3 / 0.8						
	Inrush Current (Typ) (*3)	A	40A at 230VAC, Ta=25°C (Cold Start)						
	Leakage Current (*10)	mA	< 1mA at 230VAC						
Output	Nominal Voltage	VDC	3.3	5	12	15	24	36	48
	Maximum Current	A	10		4.2	3.4	2.2	1.4	1.1
	Maximum Power	W	33	50	50.4	51	52.8	50.4	52.8
	Maximum Line Regulation (*5,6)	mV	20		48	60	96	144	192
	Maximum Load Regulation (*5,7)	mV	40		96	120	192	288	384
	Temperature Coefficient		Less than 0.02%/°C						
	Maximum Ripple & Noise (*1,4)	mVp-p	80		120			150	200
	Hold-up Time (115/230VAC)(Typ) (*1)	ms	14 / 60						
	Voltage Adjustable Range	VDC	3-3.6	4.75-5.5	10.8-13.2	13.5-16.5	22-27.2	32-40	42-54
Function	Over Current Protection (*8)	A	> 110% rated output power						
	Over Voltage Protection (*9)	VDC	3.8-4.45	5.75-6.75	13.8-16.2	17.25-20.25	27.6-32.4	41.4-48.6	55.2-64.8
	Series Operation		Possible						
Environment	Operating Temperature (*11)	°C	- 25 to + 70 (Refer to Output Derating Curve)						
	Storage Temperature	°C	- 40 to +85						
	Operating Humidity	%RH	20-90 (No dewdrop)						
	Storage Humidity	%RH	10-95 (No dewdrop)						
	Vibration		At no operating, 10 - 55Hz (sweep for 1min) 19.6m/s ² Constant, X, Y, Z 1hour each.						
	Shock (In package)		Less than 196.1m/s ²						
	Cooling		Convection cooling						
Isolation	Withstand Voltage		Input - Output : 3.0kVAC (20mA), Input - FG : 1.5kVAC (20mA) Output - FG : 500VAC (100mA) for 1min.						
	Isolation Resistance		Input-FG, Input-Output and Output-FG : More than 100MΩ (500VDC) at 25°C and 70%RH						
Standards	Safety Standards		Approved by UL60950-1, EN60950-1, IEC60950-1						
	PFHC		Built to meet IEC61000-3-2, -3						
	EMI		Built to meet EN55011/EN55022-B, FCC-B						
	Immunity		Built to meet EN61000-4-2 (Level 2,3), -3 (Level 3), -4 (Level 3), -5 (Level 4), -6 (Level 3), -8 (Level 4), -11						
Mechanical	Weight (Typ)	g	350						
	Size (W×H×D)	mm	99×97×36 (Refer to Outline Drawing)						

(*1) At Maximum Output Power, nominal input voltage, Ta=25°C.

(*2) For cases where conformance to various safety specs (UL, CSA, EN) are required, to be described as 100-240VAC, 50/60Hz on name plate.

(*3) Not applicable for the in-rush current to Noise Filter for less than 0.2mS.

(*4) Ripple & noise are measured at 20MHz by using a 300mm twisted pair of load wires terminated with a 0.1uF film capacitor and a 47uF electrolytic capacitor.

(*5) Measure line & load regulation at output terminal M3.5 tapped point.

(*6) 88-264VAC, constant load.

(*7) No load-Full load (Maximum power), constant input voltage.

(*8) Current limit with automatic recovery.

Avoid to operate at overload or dead short for more than 30 seconds.

(*9) OVP circuit will shutdown output, manual reset (Re-power on).

(*10) Measured by each measuring method of UL and EN (at 60Hz), Ta=25°C.

(*11) Refer to Output Derating Curve (PA582-01-02_) for details of output derating versus ambient temperature.

(*12) All parameters NOT specifically mentioned are measured at 230VAC input, rated load and Ta=25°C..

LS50 Outline Drawing

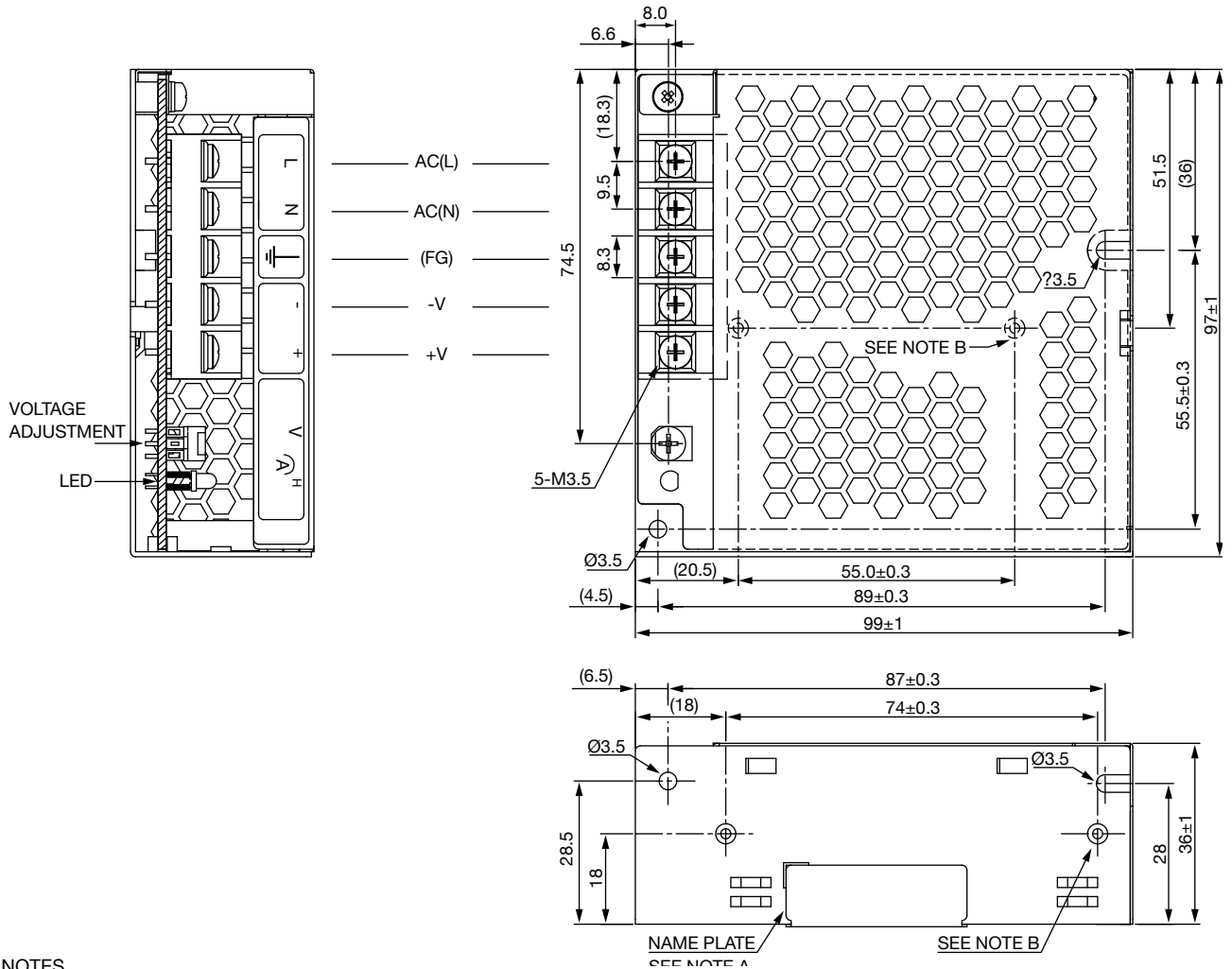

NOTES

- A. MODEL NAME, INPUT VOLTAGE RANGE, NOMINAL OUTPUT VOLTAGE, MAXIMUM OUTPUT CURRENT & COUNTRY OF MANUFACTURE ARE SHOWN IN ACCORDANCE WITH THE SPECIFICATION.
- B. M3 TAPPED, EMBOSSED & COUNTERSUNK HOLES (4) FOR CUSTOMER CHASSIS MOUNTING. SCREWS MUST NOT PROTRUDE INTO POWER SUPPLY BY MORE THAN 5mm.

LS50 Output Derating

***COOLING : CONVECTION COOLING**

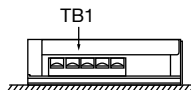
Ta (°C)	LOAD (%)	STANDARD MOUNTING
-25 to +50	100	
70	70	

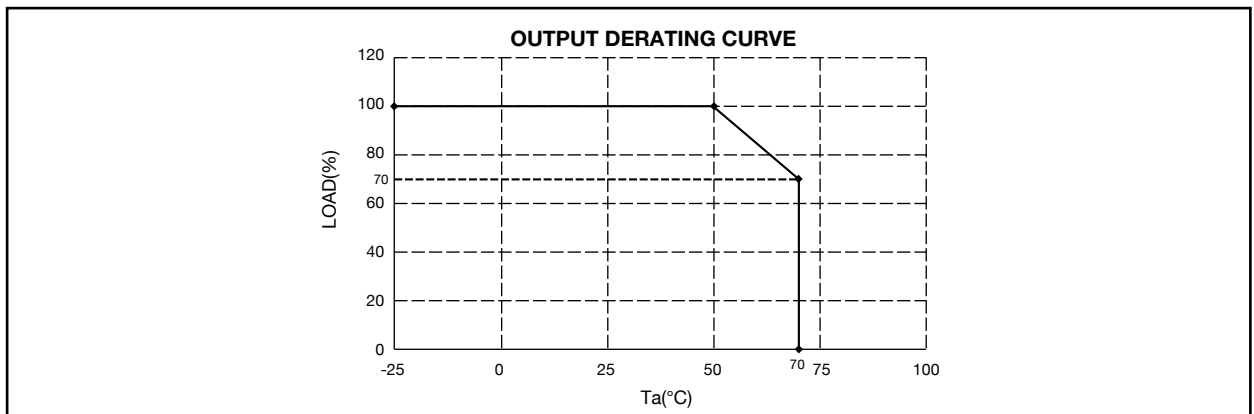

LS75 Specifications

ITEMS/UNITS		MODEL	LS75-3.3	LS75-5	LS75-12	LS75-15	LS75-24	LS75-36	LS75-48
Input	Voltage Range (*2)	V	AC88-264 or DC125-373 (Withstand AC300 Surge for 5 seconds)						
	Frequency	Hz	47-63						
	Efficiency (230VAC)(Typ) (*1)	%	75	79	84	85	86	87	
	Current (115/230VAC)(Typ) (*1)	A	1.6 / 1.0						
	Inrush Current (Typ) (*3)	A	40A at 230VAC, Ta=25°C (Cold Start)						
	Leakage Current (*10)	mA	< 1mA at 230VAC						
Output	Nominal Voltage	VDC	3.3	5	12	15	24	36	48
	Maximum Current	A	15	12	6	5	3.2	2.1	1.6
	Maximum Power	W	49.5	60	72	75	76.8	75.6	76.8
	Maximum Line Regulation (*5,6)	mV	20		48	60	96	144	192
	Maximum Load Regulation (*5,7)	mV	40		96	120	192	288	384
	Temperature Coefficient		Less than 0.02%/°C						
	Maximum Ripple & Noise (*1,4)	mVp-p	80		120			150	200
	Hold-up Time (115/230VAC)(Typ) (*1)	ms	14 / 60						
	Voltage Adjustable Range	VDC	3-3.6	4.75-5.5	10.8-13.2	13.5-16.5	22-27.2	32-40	42-54
Function	Over Current Protection (*8)	A	> 110% rated output power						
	Over Voltage Protection (*9)	VDC	3.8 - 4.45	5.75-6.75	13.8-16.2	17.25-20.25	27.6-32.4	41.4-48.6	55.2-64.8
	Series Operation		Possible						
	Operating Temperature (*11)	°C	- 25 to + 70 (Refer to Output Derating Curve)						
Environment	Storage Temperature	°C	- 40 to +85						
	Operating Humidity	%RH	20-90 (No dewdrop)						
	Storage Humidity	%RH	10-95 (No dewdrop)						
	Vibration		At no operating, 10 - 55Hz (sweep for 1min), 19.6m/s² Constant, X, Y, Z 1hour each.						
	Shock (In package)		Less than 196.1m/s²						
	Cooling		Convection cooling						
	Isolation	Withstand Voltage		Input - Output : 3.0kVAC (20mA), Input - FG : 1.5kVAC (20mA) Output - FG : 500VAC (100mA) for 1min.					
Isolation Resistance			Input-FG, Input-Output and Output-FG : More than 100MΩ (500VDC) at 25°C and 70%RH						
Standards	Safety Standards		Approved by UL60950-1, EN60950-1, IEC60950-1						
	PFHC		Built to meet IEC61000-3-2, -3						
	EMI		Built to meet EN55011/EN55022-B, FCC-B						
	Immunity		Built to meet EN61000-4-2 (Level 2,3), -3 (Level 3), -4 (Level 3), -5 (Level 4), -6 (Level 3), -8 (Level 4), -11						
Mechanical	Weight (Typ)	g	410						
	Size (W×H×D)	mm	129×98×38 (Refer to Outline Drawing)						

(*1) At Maximum Output Power, nominal input voltage, Ta=25°C.

(*2) For cases where conformance to various safety specs (UL, CSA, EN) are required, to be described as 100-240VAC, 50/60Hz on name plate.

(*3) Not applicable for the in-rush current to Noise Filter for less than 0.2mS.

(*4) Ripple & noise are measured at 20MHz by using a 300mm twisted pair of load wires terminated with a 0.1uF film capacitor and a 47uF electrolytic capacitor.

(*5) Measure line & load regulation at output terminal M3.5 tapped point.

(*6) 88-264VAC, constant load.

(*7) No load-Full load (Maximum power), constant input voltage.

(*8) Current limit with automatic recovery.

Avoid to operate at overload or dead short for more than 30 seconds.

(*9) OVP circuit will shutdown output, manual reset (Re-power on).

(*10) Measured by each measuring method of UL and EN (at 60Hz), Ta=25°C.

(*11) Refer to Output Derating Curve (PA582-01-02_) for details of output derating versus ambient temperature.

(*12) All parameters NOT specifically mentioned are measured at 230VAC input, rated load and Ta=25°C.

LS75 Outline Drawing

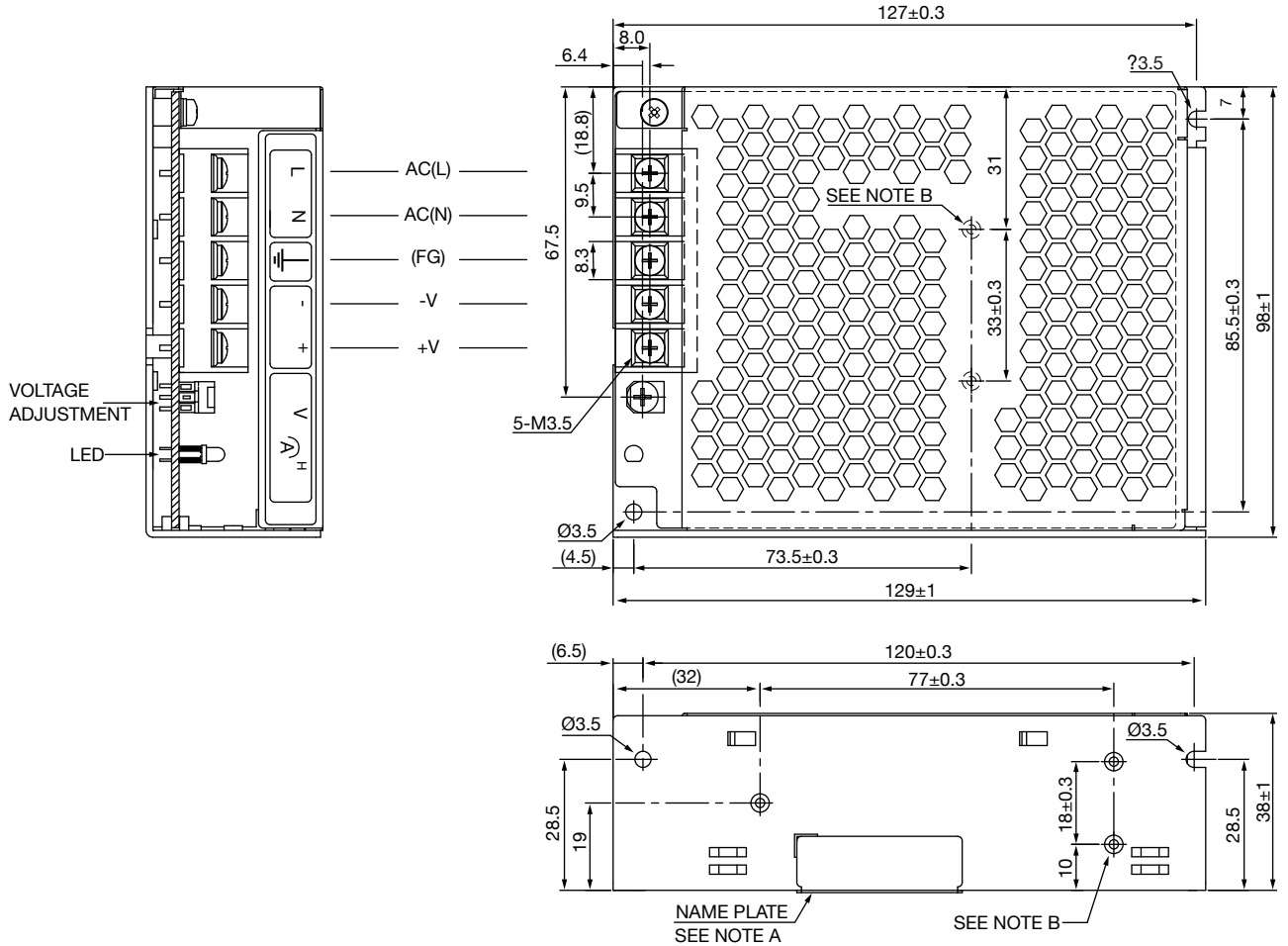

NOTES

- A. MODEL NAME, INPUT VOLTAGE RANGE, NOMINAL OUTPUT VOLTAGE, MAXIMUM OUTPUT CURRENT & COUNTRY OF MANUFACTURE ARE SHOWN IN ACCORDANCE WITH THE SPECIFICATION.
- B. M3 TAPPED, EMBOSSED & COUNTERSUNK HOLES (5) FOR CUSTOMER CHASSIS MOUNTING. SCREWS MUST NOT PROTRUDE INTO POWER SUPPLY BY MORE THAN 5mm.

LS75 Output Derating

***COOLING : CONVECTION COOLING**

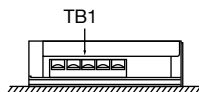
Ta(°C)	LOAD(%)	STANDARD MOUNTING
-25 to +50 70	100 70 (3.3 & 5V), 60 (OTHERS)	

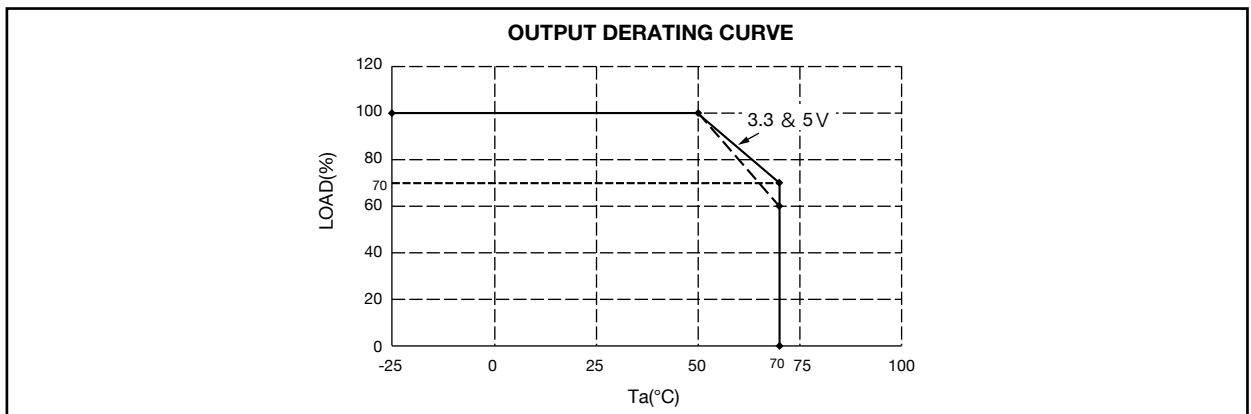

LS100 Specifications

ITEMS/UNITS		MODEL	LS100-3.3	LS100-5	LS100-12	LS100-15	LS100-24	LS100-36	LS100-48
Input	Voltage Range (*2)(*13)	V	AC88 - 264 or DC125 - 373 (Withstand AC300 Surge for 5 seconds)						
	Frequency (*2)	Hz	47 - 63						
	Efficiency(230VAC)(typ) (*1)	%	75	79	82	84	86		
	Current(115/230VAC)(typ) (*1)	A	2.2 / 1.2						
	Inrush Current(typ) (*3)	A	60A at 230VAC, Ta=25°C (Cold Start)						
	Leakage Current (*10)	mA	< 1mA at 230VAC, 60Hz						
Output	Nominal Voltage	VDC	3.3	5	12	15	24	36	48
	Maximum Current	A	20	16	8.5	7	4.5	3	2.3
	Maximum Power	W	66	80	102	105	108		110.4
	Maximum Line Regulation (*5)(*6)	mV	20		48	60	96	144	192
	Maximum Load Regulation (*5)(*7)	mV	40		96	120	192	288	384
	Temperature Coefficient		Less than 0.02%/°C						
	Maximum Ripple & Noise (*1)(*4)	mVp-p	80		120			150	200
	Hold-up Time(115/230VAC)(typ) (*1)	ms	25 / 150						
	Voltage Adjustable Range	VDC	3 - 3.6	4.75 - 5.5	10.8 - 13.2	13.5 - 16.5	22 - 27.2	32 - 40	42 - 54
Function	Over Current Protection (*8)	A	> 110% rated output power						
	Over Voltage Protection (*9)	VDC	3.8 - 4.45	5.75 - 6.75	13.8 - 16.2	17.25 - 20.25	27.6 - 32.4	41.4 - 48.6	55.2 - 64.8
	Series Operation		Possible						
Environment	Operating Temperature (*11)	°C	- 25 - + 70 (Refer to Output Derating Curve)						
	Storage Temperature	°C	- 40 - +85						
	Operating Humidity	%RH	20 - 90 (No dewdrop)						
	Storage Humidity	%RH	10 - 95 (No dewdrop)						
	Vibration		At no operating, 10 - 55Hz (sweep for 1min) 19.6m/s ² Constant, X, Y, Z 1hour each.						
	Shock(In Package)		Less than 196.1m/s ²						
	Cooling		Convection cooling						
Isolation	Withstand Voltage		Input - Output : 3.0kVAC (20mA), Input - FG : 1.5kVAC (20mA) Output - FG : 500VAC (100mA) for 1min.						
	Isolation Resistance		Input - FG, Input - Output and Output - FG: More than 100MΩ (500VDC) at 25°C and 70%RH						
Standards	Safety Standards		Approved by UL60950-1, EN60950-1, IEC60950-1						
	PFHC		Built to meet IEC61000-3-2, -3						
	EMI		Built to meet EN55011/EN55022-B, FCC-B						
	Immunity		Built to meet EN61000-4-2 (Level 2,3), -3 (Level 3), -4 (Level 3), -5 (Level 4), -6 (Level 3), -8 (Level 4), -11						
Mechanical	Weight(typ)	g	600						
	Size (W×H×D)	mm	159 x 97 x 38 (Refer to Outline Drawing)						

(*1) At Maximum Output Power, nominal input voltage, Ta = 25°C.

(*2) For cases where conformance to various safety specs (UL, CSA, EN) are required, to be described as 100 - 240VAC, 50 / 60Hz on name plate.

(*3) Not applicable for the in-rush current to Noise Filter for less than 0.2mS.

(*4) Ripple & noise are measured at 20MHz by using a 300mm twisted pair of load wires terminated with a 0.1uF film capacitor and a 47uF electrolytic capacitor.

(*5) Measure line & load regulation at output terminal M3.5 tapped point.

(*6) 88 - 264VAC, constant load.

(*7) No load - Full load (Maximum power), constant input voltage.

(*8) Current limit with automatic recovery. Avoid to operate at overload or dead short for more than 30 seconds.

(*9) OVP circuit will shutdown output, manual reset (Re-power on).

(*10) Measured by each measuring method of UL and EN (at 60Hz), Ta=25°C.

(*11) Refer to Output Derating Curve (PA577-01-02_) for details of output derating versus ambient temperature.

(*12) All parameters NOT specifically mentioned are measured at 230VAC input, rated load and Ta = 25°C.

(*13) Refer to Output Derating Curve (PA577-01-03_) for details of output derating versus input voltage.

LS100 Outline Drawing

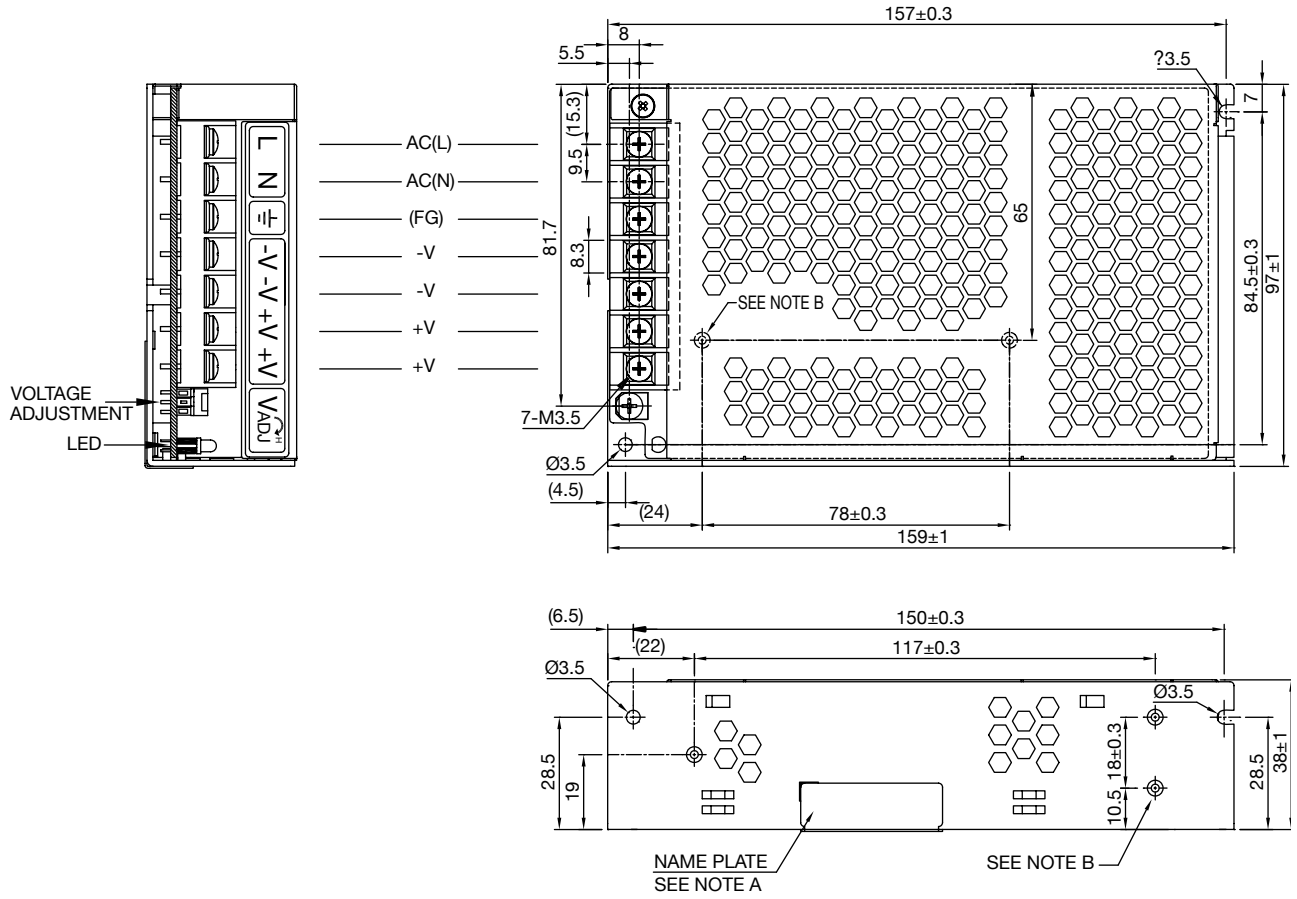

NOTES

- A. MODEL NAME NOMINAL OUTPUT VOLTAGE AND MAXIMUM OUTPUT CURRENT ARE SHOWN IN THE NAME PLATE IN ACCORDANCE WITH THE SPECIFICATION.
- B. M3 TAPPED & EMBOSSED & COUNTERSUNK HOLES (5) FOR CUSTOMER CHASSIS MOUNTING. SCREW MUST NOT PROTRUDE INTO POWER SUPPLY BY MORE THAN 5mm.

LS100 Output Derating

***COOLING : CONVECTION COOLING**

Ta(°C)	LOAD(%)	STANDARD MOUNTING
-25 to +45	100	
50	92 (3.3 & 5V), 100 (OTHERS)	
70	60	

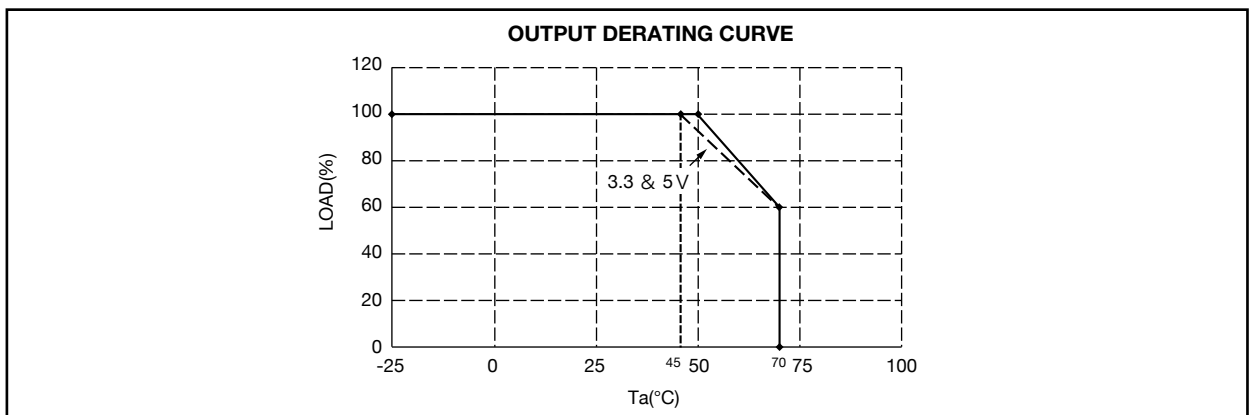

LS150 Specifications

ITEMS/UNITS		MODEL	LS150-3.3	LS150-5	LS150-12	LS150-15	LS150-24	LS150-36	LS150-48
Input	Voltage Range (*2)	V	AC88 - 132 / AC176 - 264 Input Selectable or DC248 - 373 (Withstand AC300 Surge for 5 seconds)						
	Frequency (*2)	Hz	47-63						
	Efficiency(230VAC)(typ) (*1)	%	75	79	83	85	86	87	
	Current(115/230VAC)(typ) (*1)	A	3.5 / 2.0						
	Inrush Current(typ) (*3)	A	40A at 230VAC, Ta=25°C (Cold Start)						
	Leakage Current (*10)	mA	< 1mA at 230VAC, 60Hz						
Output	Nominal Voltage	VDC	3.3	5	12	15	24	36	48
	Maximum Current	A	30	26	12.5	10	6.5	4.3	3.3
	Maximum Power	W	99	130	150		156	154.8	158.4
	Maximum Line Regulation (*5)(*6)	mV	20		48	60	96	144	192
	Maximum Load Regulation (*5)(*7)	mV	40		96	120	192	288	384
	Temperature Coefficient		Less than 0.02%/°C						
	Maximum Ripple & Noise (*1)(*4)	mVp-p	80		120			150	200
	Hold-up Time(115/230VAC)(typ) (*1)	ms	25 / 30						
	Voltage Adjustable Range	VDC	3 - 3.6	4.75 - 5.5	10.8 - 13.2	13.5 - 16.5	22 - 27.2	32 - 40	42 - 54
Function	Over Current Protection (*8)	A	> 110% rated output power						
	Over Voltage Protection (*9)	VDC	3.8 - 4.45	5.75 - 6.75	13.8 - 16.2	17.25 - 20.25	27.6 - 32.4	41.4 - 48.6	55.2 - 64.8
	Series Operation		Possible						
Environment	Operating Temperature (*11)	°C	- 25 - + 70 (Refer to Output Derating Curve)						
	Storage Temperature	°C	- 40 - +85						
	Operating Humidity	%RH	20 - 90 (No dewdrop)						
	Storage Humidity	%RH	10 - 95 (No dewdrop)						
	Vibration		At no operating, 10 - 55Hz (sweep for 1min) 19.6m/s ² Constant, X, Y, Z 1hour each.						
	Shock(In Package)		Less than 196.1m/s ²						
	Cooling		Convection cooling						
	Isolation	Withstand Voltage		Input - Output : 3.0kVAC (20mA), Input - FG : 1.5kVAC (20mA) Output - FG : 500VAC (100mA) for 1min.					
Isolation Resistance			Input - FG, Input - Output and Output - FG: More than 100MΩ (500VDC) at 25°C and 70%RH						
Standards	Safety Standards		Approved by UL60950-1, EN60950-1, IEC60950-1						
	PFHC(230VAC) (*1)		Built to meet IEC61000-3-2, -3						
	EMI		Built to meet EN55011/EN55022-B, FCC-B						
Mechanical	Immunity		Built to meet EN61000-4-2 (Level 2,3), -3 (Level 3), -4 (Level 3), -5 (Level 4), -6 (Level 3), -8 (Level 4), -11						
	Weight(typ)	g	700						
	Size (W×H×D)	mm	199 x 98 x 38 (Refer to Outline Drawing)						

(*1) At Maximum Output Power, nominal input voltage, Ta = 25°C.

(*2) For cases where conformance to various safety specs (UL, CSA, EN) are required, to be described as 100 - 240VAC, 50 / 60Hz on name plate.

(*3) Not applicable for the in-rush current to Noise Filter for less than 0.2mS.

(*4) Ripple & noise are measured at 20MHz by using a 300mm twisted pair of load wires terminated with a 0.1uF film capacitor and a 47uF electrolytic capacitor.

(*5) Measure line & load regulation at output terminal M3.5 tapped point.

(*6) 88 - 132VAC or 176 - 264VAC, constant load.

(*7) No load - Full load (Maximum power), constant input voltage.

(*8) Current limit with automatic recovery. Avoid to operate at overload or dead short for more than 30 seconds.

(*9) OVP circuit will shutdown output, manual reset (Re-power on).

(*10) Measured by each measuring method of UL and EN (at 60Hz), Ta=25°C.

(*11) Refer to Output Derating Curve (PA579-01-02_) for details of output derating versus ambient temperature and mounting method.

(*12) All parameters NOT specifically mentioned are measured at 115/230VAC input, rated load and Ta = 25°C.

LS150 Outline Drawing

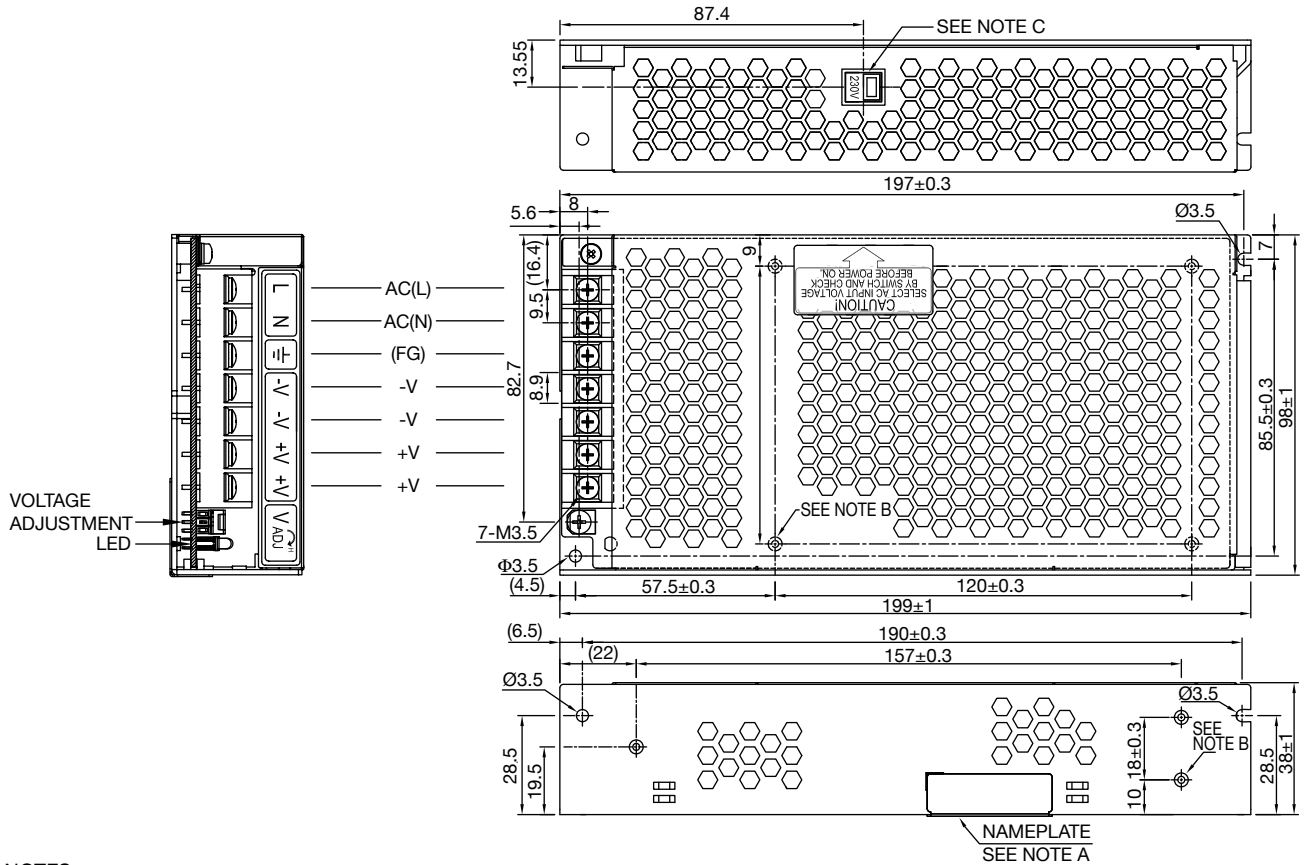

- NOTES**
- A. MODEL NAME NOMINAL OUTPUT VOLTAGE AND MAXIMUM OUTPUT CURRENT ARE SHOWN IN THE NAME PLATE IN ACCORDANCE WITH THE SPECIFICATION.
 - B. M3 TAPPED & EMBOSSED & COUNTERSUNK HOLES (7) FOR CUSTOMER CHASSIS MOUNTING. SCREW MUST NOT PROTRUDE INTO POWER SUPPLY BY MORE THAN 5mm.
 - C. SWITCH IS SELECTED TO 230V BEFORE SHIPMENT.

LS150 Output Derating

***COOLING : CONVECTION COOLING**

Ta(°C)	LOAD(%)	STANDARD MOUNTING
-25 to +40	100	
50	83.3 (3.3 & 5V), 100 (OTHERS)	
70	50 (3.3 & 5V), 70 (OTHERS)	

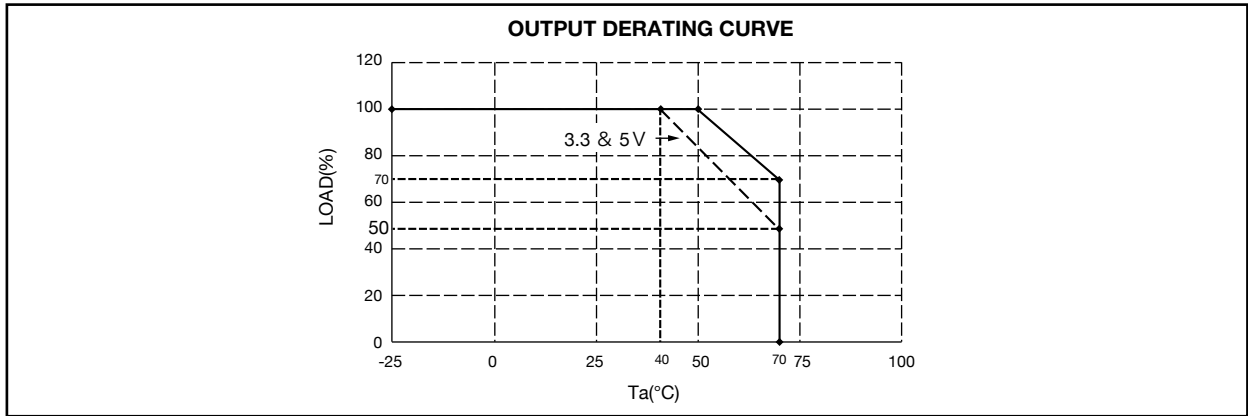

• All specifications are subject to change without notice.

LS25 Block Diagram

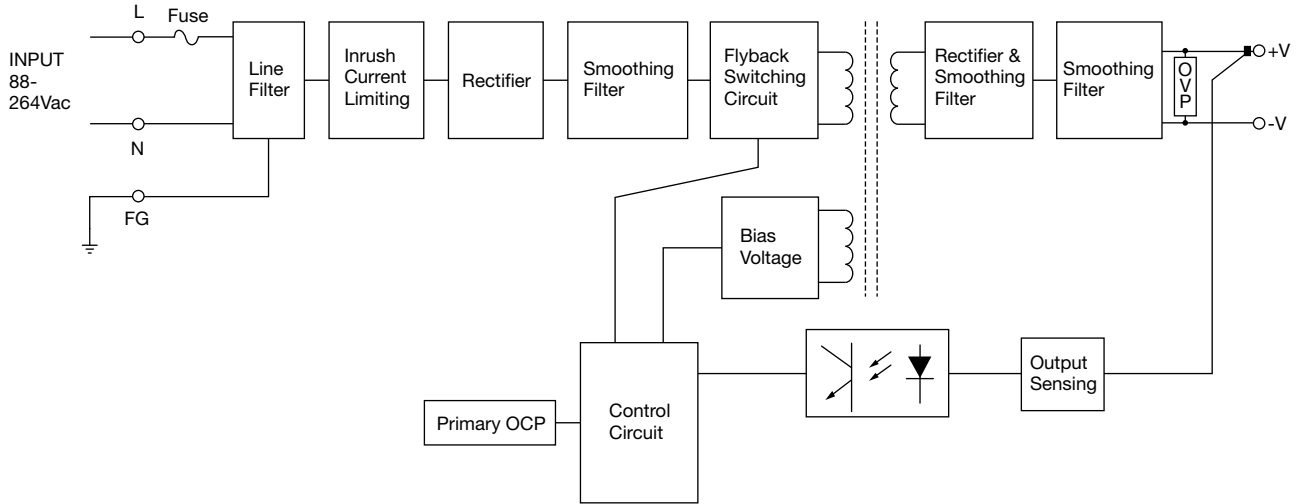

LS35, LS50, LS75 Block Diagram

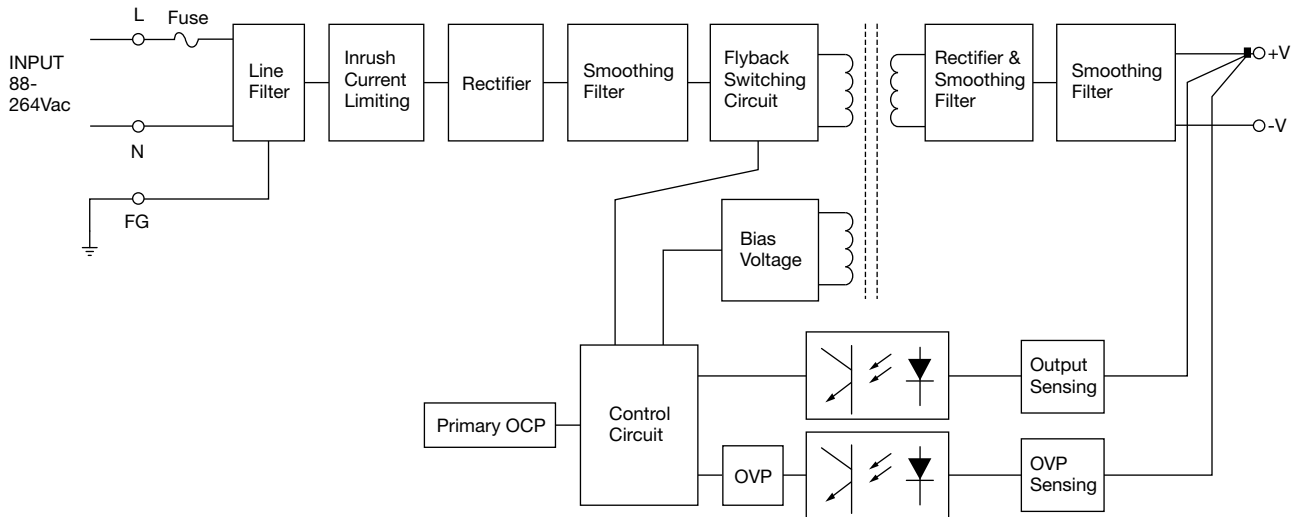

LS100 Block Diagram

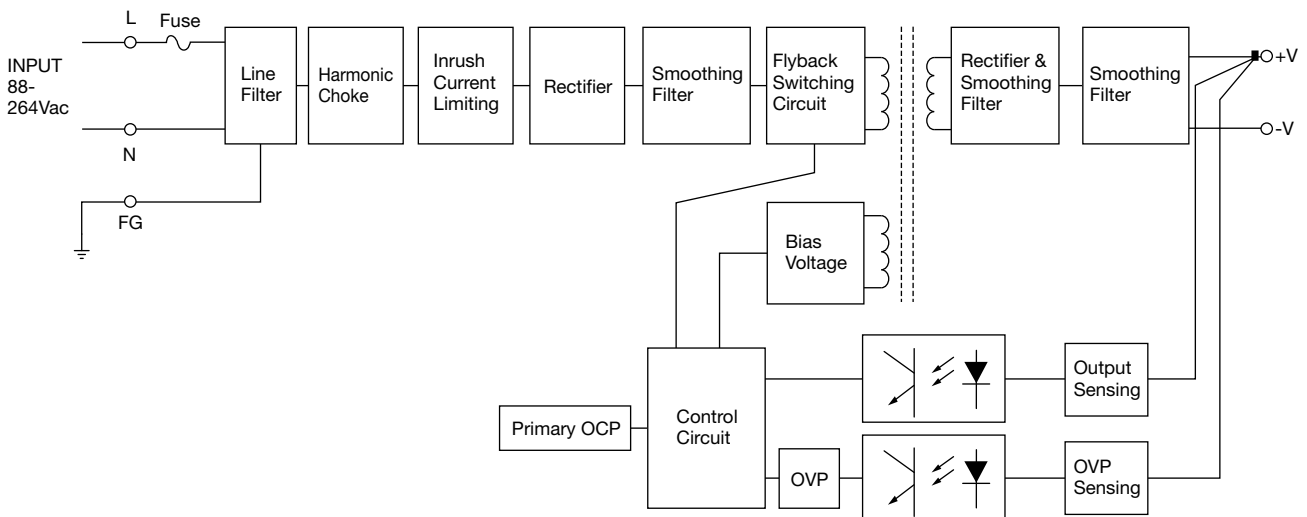

LS150 Block Diagram

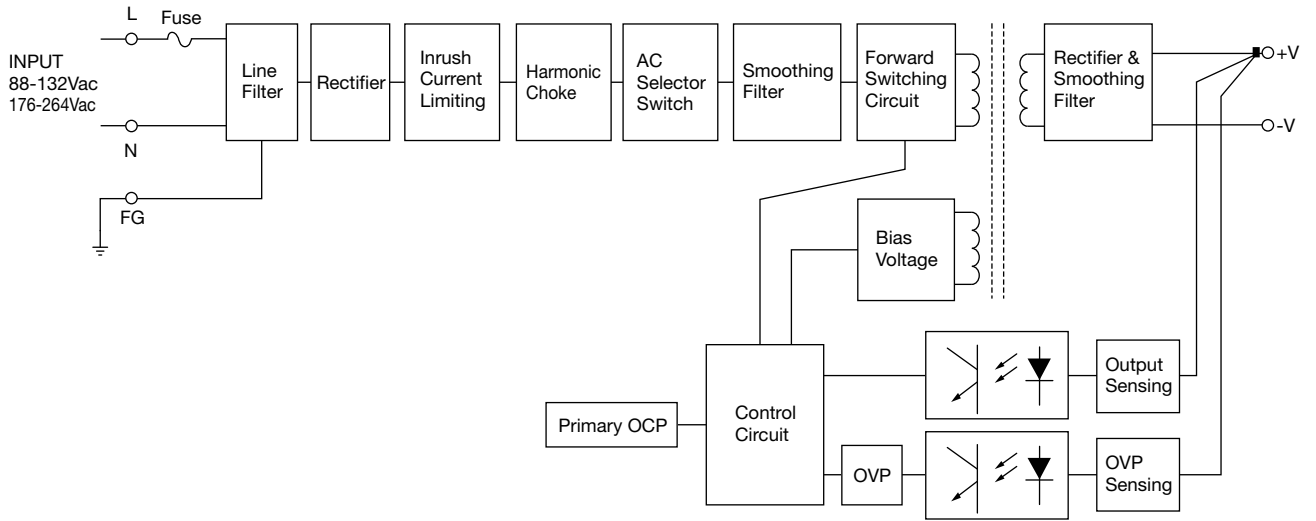

Sequence Time Chart

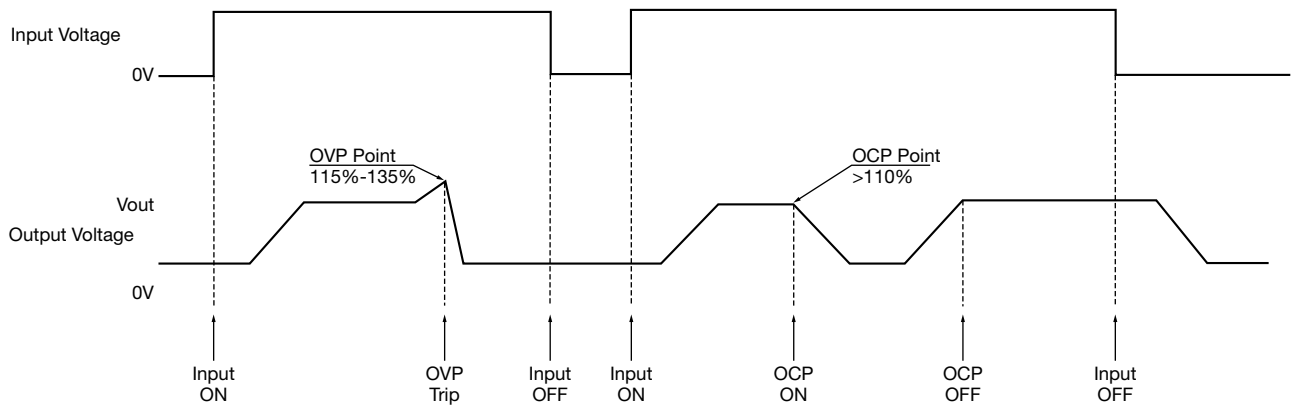

NOTE : For LS 25, OVP function will cause the output into "hiccup" mode and damage the unit.

LS Instruction Manual

BEFORE USING THE POWER SUPPLY UNIT

Pay attention to all warnings and cautions before using the unit. Incorrect usage could lead to an electrical shock, damage to the unit or a fire hazard.

⚠ WARNING and CAUTION

- Do not modify.
- Do not touch the internal components, they may have high voltage or high temperature. You may get electrical shock or burned.
- When the unit is operating, keep your hands and face away from it as you may be injured by flying debris in the event of a fault.
- This power supply is designed for use within an end product. Stick the WARNING label for users on the system equipment and notify in the system instruction manual.

- Never operate the unit under over current or short-circuit conditions for more than 30 seconds or outside its specified Input Voltage Range. Insulation failure, burning, smoke or other damage may occur.
- Confirm connections to input/output terminals are correct as indicated in the instruction manual.
- This power supply has a possibility for hazardous voltage to appear at output terminal depending on the type of failure. The outputs of these products must be earthed at in the end equipment to maintain SELV. If the outputs are not earthed, they must be considered hazardous and must not be made user accessible.

⚠ CE MARKING

CE marking, when applied to the LS series products, indicates compliance with the Low Voltage Directive (2006/95/EC) in that it complies with EN60950-1.

1. Terminal Explanation

LS25, LS35, LS50, LS75

- (1) L : Input terminal Live line (Fuse in line)
- (2) N : Input terminal Neutral line
- (3) FG ↓ : Functional Ground
- (4) -V : -Output terminal
- (5) +V : +Output terminal
- (6) Output voltage adjustable trimmer
- (7) Output monitoring indicator (Green LED : ON)

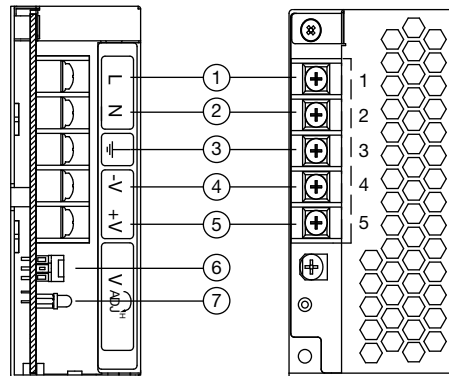

LS100, LS150

- (1) L : Input terminal Live line (Fuse in line)
- (2) N : Input terminal Neutral line
- (3) FG ↓ : Functional Ground
- (4) -V : -Output terminal (25A max./terminal)
- (5) +V : +Output terminal (25A max./terminal)
- (6) Output voltage adjustable trimmer
- (7) Output monitoring indicator (Green LED : ON)

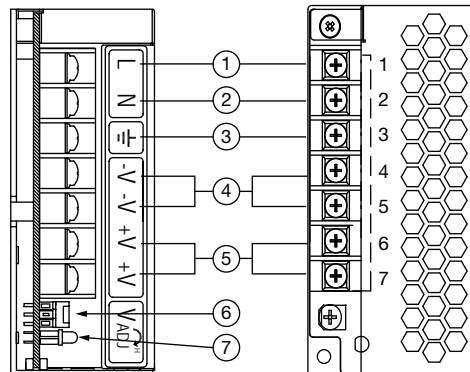

2. Terminal connecting method

- Input must be off when making connection.
- Connect FG terminal to ground terminal of the equipment.
- The output load line and input line shall be separated and twisted to improve noise immunity.

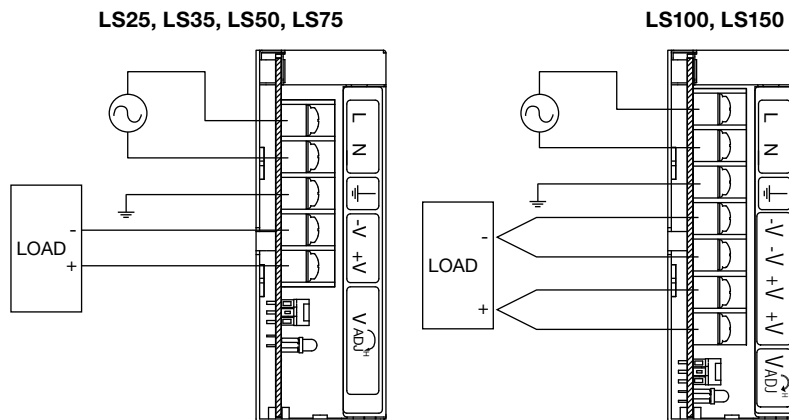

Maximum output current of each output terminal is 25A except for LS25 (15A).
If more than 25A, use 2 terminals

3. Explanation of Functions and Precautions

1 Input Voltage Range

Input voltage range is single phase 88 - 264VAC (47 - 63Hz) or 125 - 373VDC for LS25 to LS100.
For LS150, selectable switch 115/230VAC will decide the input voltage range as mentioned in the table below.
Input voltage which is out of specification, may damage the unit. For cases where conformance to various safety specs(UL,CSA,EN) are required, input voltage range will be 100 - 240VAC (50/60Hz).
Note : LS series able to withstand Input Surge of 300VAC for 5 seconds.

LS150 – Selectable voltage range

Selected Range	Applicable Input Voltage Range in VAC	Applicable Input Voltage Range in VDC
115	88 - 132	NA
230	176 - 264	248 - 373

2 Output Voltage Range

V.ADJ trimmer is for output voltage adjustment within the range of specifications. Turning the trimmer clockwise will increase the output voltage. Note over voltage protection (OVP) function may trigger if the output voltage is increased excessively.

3 Inrush Current

Power Thermistor is built in to protect the circuit from Inrush Current. Please select suitable input switch and fuse rating in case of re-input the power at high temperature.

4 Over Voltage Protection (OVP)

The OVP function will shutdown the output except for LS25. The input need to be removed for a few minutes, and then re-input for recovery of the output. OVP setting is fixed and cannot be adjusted externally.
Note : For LS25, OVP function will cause the output into "hiccup" mode and damage the unit.

5 Over Current Protection (OCP)

OCP function operates when the output current exceeds OCP specifications. The output will automatically recover when the overload condition is removed. Do not operate overload or dead short conditions for more than 30 seconds, which could result in damage or insulation failure.

6 Output Ripple & Noise

Ripple & noise are measured at 20MHz by using a 300mm twisted pair of load wires terminated with a 0.1uF film capacitor & 47uF electrolytic capacitor. When load lines are longer, ripple becomes larger. The output ripple cannot be measured accurately if the probe ground lead of oscilloscope is too long. At low temperature, large ripple & noise may also be observed due to large ESR of the internal Electrolytic Capacitors especially at -25degC. Output voltage rise may not be smooth during initial turn on at low temperature.

7 Series Operation

For series operation, either method (A) or (B) is possible.

Method (A)

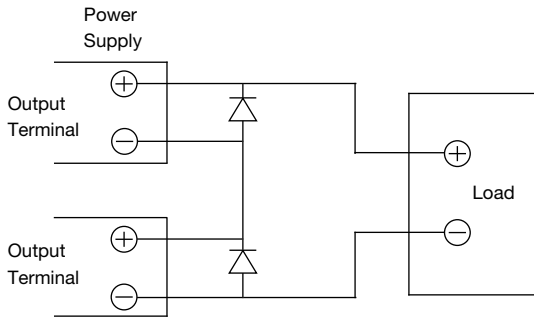

Method (B)

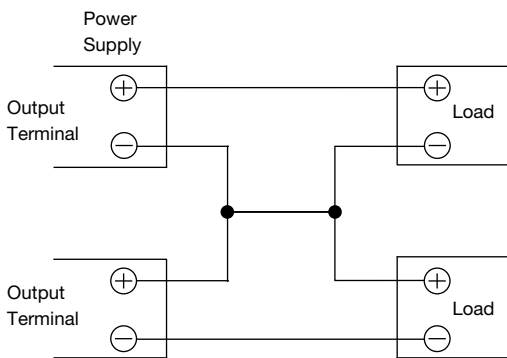

Note : In case of Method (A), please connect diodes to prevent the reverse voltage.

8 Parallel Operation

(A) Operation to increase the Output Current is not possible.

(B) Operation as a Backup Power Supply is possible as follows.

1. Set the power supply output voltage higher by the amount of forward voltage drop (V_F) of the diode.
2. Please adjust the output voltage of each power supply to be the same.
3. Please use within the specifications for output voltage and output current.

(A)

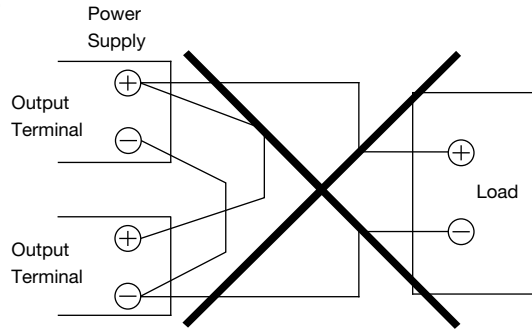

(B)

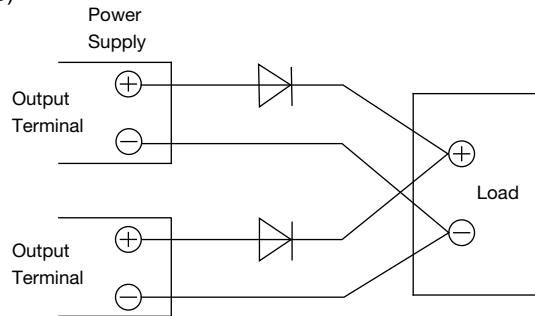

4. Isolation / Withstand Voltage

1 Isolation Test

Isolation resistance between output and FG (chassis) shall be more than 100MΩ at 500VDC. For safety, voltage setting of DC isolation tester must be done before the test. Ensure that the unit is fully discharged after the test.

(A) Output - FG (chassis) : 500VDC, 100MΩ or more

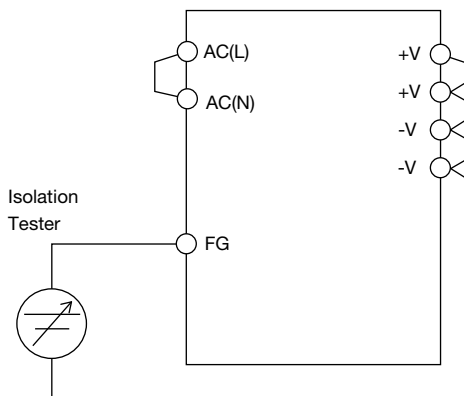

2 Withstand Voltage

This series is designed to withstand 3.0kVAC between input and output, 1.5kVAC between input and FG (chassis) and 500VAC between output and FG (chassis) each for 1 minute. When testing withstand voltage, set current limit of withstand voltage test equipment at 20mA (Output-FG (chassis) : 100mA). The applied voltage must be gradually increased from zero to testing value and then gradually decreased for shut down. When timer is used, the power supply may be damaged by high impulse voltage at timer switch on and off. Connect input and output as follows.

(a) Input - FG (chassis) : solid line 1.5kVAC, 1min (20mA)

(b) Input - Output : dotted line 3kVAC, 1min (20mA)

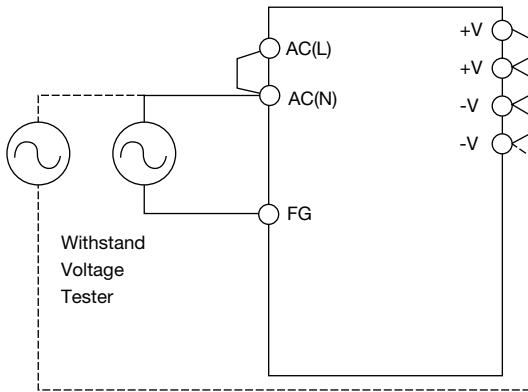

(c) Output - FG (chassis) : 500VAC, 1min (100mA)

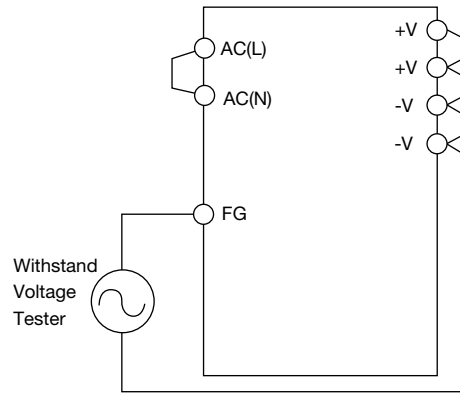

5. Mounting Directions

1 Output Derating according to the Mounting Directions

Recommended standard mounting is Method (A). Method (B), (C) and (D) are also possible. Refer to the Output Derating below. Please do not use installation Method (E), where the PCB will be on the topside and heat will be trapped inside the unit. In the following derating curve, the maximum output current is denoted as 100%.

STANDARD MOUNTING (A)

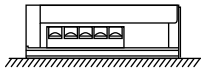

(B)

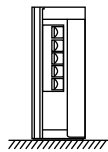

(C)

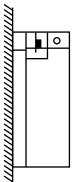

(D)



(E) Not Possible

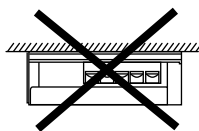

(1) Output Derating versus Ambient Temperature (Convection Cooling)

LS25-3.3

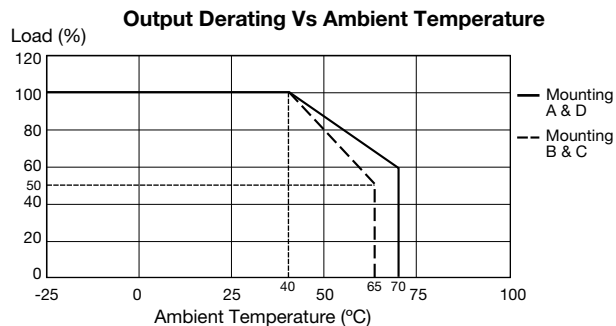

LS25-5, -12, -15, -24, -36 & -48

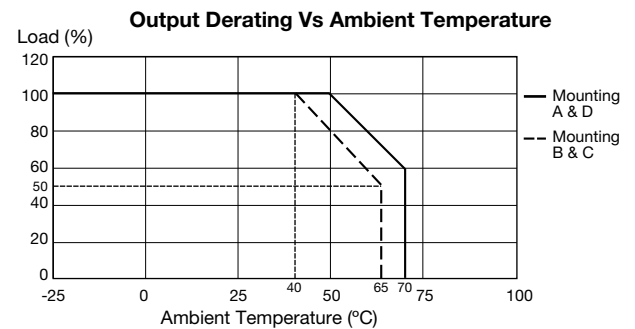

LS35-3.3, -5, -12, -15, -24, -36 & -48

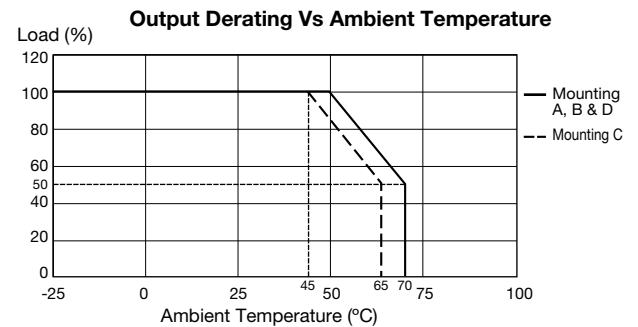

LS50-3.3, -5, -12, -15, -24, -36 & -48

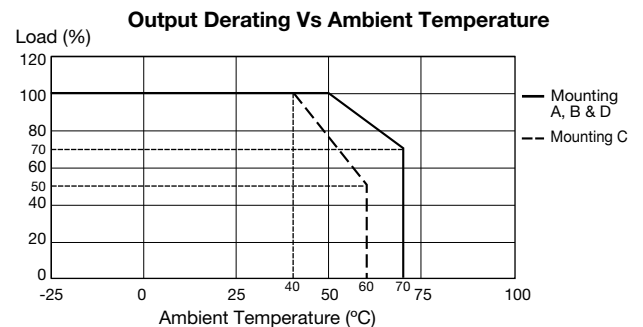

LS75-3.3, -5

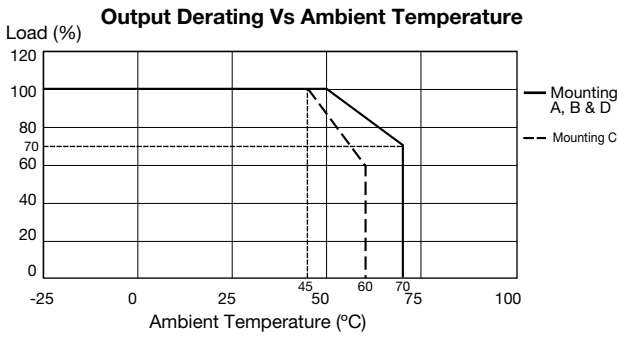

LS150 -12, -15, -24, -36 & -48

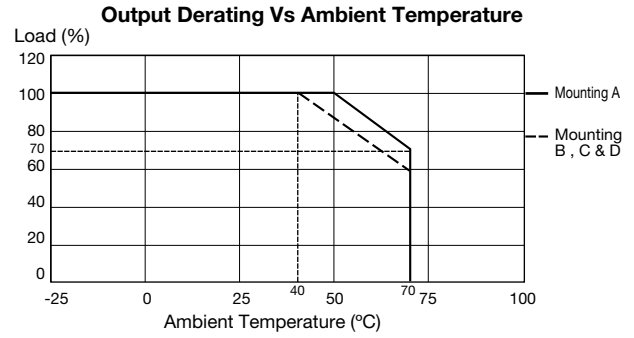

LS75-12, -15, -24, -36 & -48

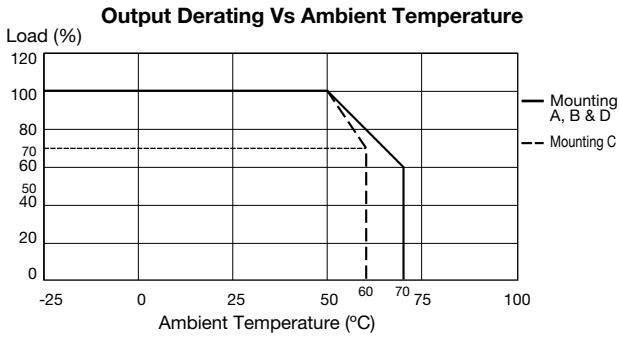

(2) Output Derating versus Input Voltage (Convection Cooling)

LS100 -3.3, -5, -12, -15, -24, -36 & -48

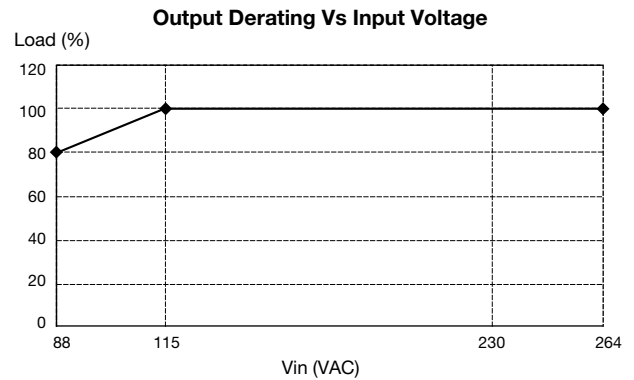

NOTE : LS25, LS35, LS50, LS75 & LS150 series do not require Input Voltage Derating.

LS100 -3.3, -5

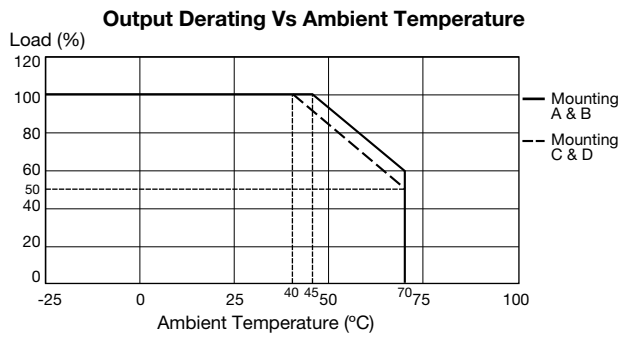

LS100 -12, -15, -24, -36 & -48

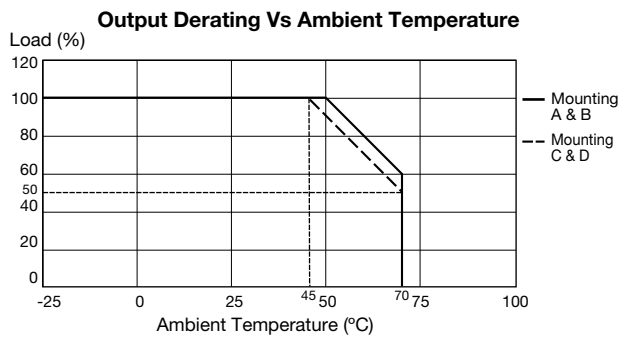

LS150 -3.3, -5

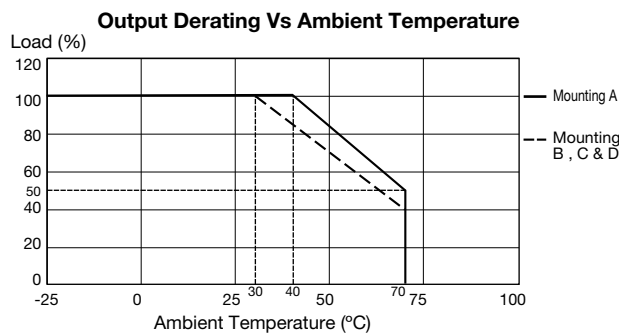

2 Mounting Method

- (1) This is convection cooling type power supply. In consideration of the heat radiation and safety, please keep a distance of more than 15mm between the power supply and the peripheral parts. When lining up multiple units, please make sure to place them 15mm or more apart from each other.
- (2) Maximum allowable penetration of mounting screws into the power-supply is 5mm except LS25 (4mm).
- (3) Recommended torque for mounting screws of LS25 to LS150 (M3 screw) : 0.49 N·m (5.0 kgf·cm).

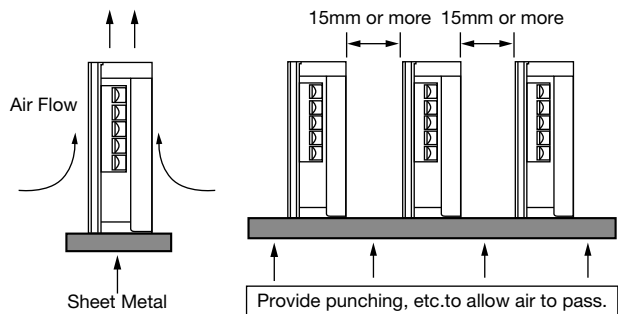

6. Wiring Method

- The input and output load wires shall be separated and twisted to improve noise immunity.
- Both wires must be as thick and short as possible to make lower impedance.
- Noise can be reduced by connecting a film capacitor with 0.1uF capacitance across the load terminals.
- For safety and EMI considerations, connect the FG terminal of LS series to mounting set ground terminal.
- The recommended wire type :

MODEL	Recommended Wire	Recommended torque	Recommended crimp-type terminal		
			D (MAX)	t (MAX)	Mounting Pieces (MAX)
LS25	AWG16-22	M3.0 Screws 0.49 N·m (5.0 kgf·cm)	6.0mm	0.8mm	2 piece
LS35- LS150	AWG14-22	M3.5 Screws 1.0 N·m (9.8 kgf·cm) - 1.4 N·m (13.7 kgf·cm)	6.8mm	0.8mm	2 piece

Note 1 : When using separate loads, it is recommended to use 2 pieces of 0.8mm thick crimp-type terminal.

Note 2 : For recommended wire diameter, refer to wire maker recommended allowable current and voltage drop.

For higher output current model like 3.3V & 5V, bigger diameter wire is recommended.

7. External Fuse Rating

Refer to the following fuse rating when selecting the external input fuse. Surge current flows when input turns on. Fuse rating is specified by Inrush Current value at input turn on. Do not select the fuse according to input current (rms) values under the actual load condition.

LS25	:	F1.6A , 250V
LS35, LS50	:	T2A , 250V
LS75	:	T2.5A, 250V
LS100	:	F4A, 250V
LS150	:	F5A, 250V

8. Before concluding that the unit is at fault, make the following checks.

- Check if the rated input voltage is connected.
- Check if the wiring of input and output is correct.
- Check if the wire size is correct.
- Check if the output voltage control (V.ADJ) is properly adjusted.
- Check if the output current and output wattage does not exceed the specification.
- Ensure that a large capacitor is not connected across the output terminals. Please use within maximum capacitance shown below.

MODEL	Maximum external capacitance						
	3.3V	5V	12V	15V	24V	36V	48V
LS25	10,000uF		5,000uF	2,000uF	1,000uF	500uF	
L35 - LS50	10,000uF		5,000uF		2,000uF	500uF	
LS75 - LS150	10,000uF			5,000uF		1,000uF	

NOTE : It is normal to hear audible noise from power-supply under Dynamic Load operation or if the input voltage waveform is not sinusoidal.

9. Warranty Condition

This product is under warranty for 3 years (based on 8 hours/day operation) from the date of shipment. During the warranty period, TDK-Lambda will, at it's option, either repair or replace products prove to be defective.

Warranty applies but not limited to the following.

- Average operating temperature (ambient temperature of the power supply unit) is under 40°C.
- Average load factor is 80% or less.
- Installation method : Standard installation.

Following cases are not covered by warranty.

- Improper usage and mis-handling like dropping or applying shock to the unit and defects from operation exceeding specification of the product.
- Defects resulting from natural disaster (fire, flood).
- Unauthorized modification or repair.