

MTC35-150



- Page 2 - MTC35-50
- Page 15 - MTC75-150

MTC35 & 50



- COTS Component for Defense & Avionics Applications
- Environmental Performance to MIL-STD 810
- 10 to 50 VDC Transient Input Range
- 10 to 40 VDC Steady State Input Range
- -55 °C to 100 °C Operation
- Cooling Plates and Mounting Holes for Easy Integration
- Synchronous Rectification on Low Voltage Outputs
- MIL-STD 461 and DEF-STAN 59-11
- MIL-STD 1275 and DEF-STAN 61-5
- Frequency Synchronization
- Thermal Warning Signal

The MTC35 & 50 are COTS DC-DC converters developed specifically for the defense and avionics market. These products have full military specifications while offering the short lead-times and cost benefits of a COTS component.

The products offer excellent size, efficiency and EMC performance and the input range is designed to provide short term operation over 10-50 VDC to enable the converter to work at full power through the dips and surges commonly seen in vehicle and aircraft applications.

Comprehensive control functions such as voltage trim, remote sense, remote on/off and frequency synchronization to an external source are standard features. The MTC35 & 50 contain an over temperature warning signal that gives user control over the temperature shutdown function of the converter.

When used in conjunction with the DSF and FSO input filter module the MTC35 & 50 are compliant to MIL-STD 461F CE/CS, MIL-STD1275A-D and MIL-STD 704B-F as well as DEF-STAN-59-411 and DEF-STAN 61-5 part 6 issue 5.



T H E X P E R T S I N P O W E R

Input Characteristics

Characteristic	Minimum	Typical	Maximum	Units	Notes & Conditions
Input Voltage	10	28	40	VDC	Continuous
Transient Input Voltage Range	10		50	VDC	50 VDC for 100 ms
UVLO Turn On	9.5			VDC	
UVLO Turn Off			8.8	VDC	
Input Current					See models and ratings table, typical and measured at 28 VDC input
Inhibited Input Current			4	mA	
Inrush Current			40	A	Peak value
Input Reverse Voltage Protection					External components required

Output Characteristics

Characteristic	Minimum	Typical	Maximum	Units	Notes & Conditions
Output Voltage				VDC	See models and ratings table for details
Output Voltage Adjustment	-20		+10	%	-10% min voltage trim for 3V3 version
Output Current				A	See models and ratings table for details
Output Set Tolerance			±1.5	%	
Minimum Load Single O/P	0			A	No minimum load required
Ripple & Noise			50	mV	Pk-pk at 100% load and 20 MHz bandwidth
Vout ≤5V Vout >5V			100		
Overvoltage Protection	120		140	%	Vout nominal
Overload Protection	110		140	%	At Vin nominal, see figure 3
Short Circuit Protection					Output turns off until the short is removed
Overtemperature Protection			105	°C	Baseplate Temperature
Remote Sense			10	%	Total voltage compensation. Includes Vtrim. See fig 4.
Load Regulation Single O/P		1		%	Vout nominal
Transient Response			±4	%	Recovery within 1% in less than 500µs for a 50% load change at 0.1A/µs
Line Regulation			±1	%	Vout nominal at 10-40 Vin
Maximum Output Capacitance			300 x Iout max	µF	For start up within 100 ms
Start Up Time			100	ms	
Start Up Rise Time			20	ms	
Temperature Coefficient			0.3	%/°C	

Models & Ratings

Output Power	Output Voltage	Output Current	Input Current ⁽¹⁾		Efficiency ⁽¹⁾	Model Number
			No Load	Full Load		
35 W	3.3 VDC	10.00 A	100 mA	1.49 A	84%	MTC3528S3V3
35 W	5.0 VDC	7.00 A	100 mA	1.45 A	86%	MTC3528S05
35 W	12.0 VDC	2.90 A	100 mA	1.41 A	88%	MTC3528S12
35 W	15.0 VDC	2.30 A	100 mA	1.40 A	88%	MTC3528S15
35 W	28.0 VDC	1.30 A	100 mA	1.48 A	88%	MTC3528S28
50 W	3.3 VDC	15.00 A	100 mA	2.18 A	82%	MTC5028S3V3
50 W	5.0 VDC	10.00 A	60 mA	2.15 A	83%	MTC5028S05
50 W	12.0 VDC	4.20 A	70 mA	2.13 A	84%	MTC5028S12
50 W	15.0 VDC	3.33 A	70 mA	2.13 A	84%	MTC5028S15
50 W	28.0 VDC	1.80 A	120 mA	2.15 A	83%	MTC5028S28

Note: 1. Typical and measured at 28 V input

2. Total of voltage trim and remote sense is +10% max.

General Specifications

Characteristic	Minimum	Typical	Maximum	Units	Notes & Conditions
Efficiency		85		%	See models table and performance graphs (fig. 28-34)
Isolation Voltage	1500			VDC	Input to output
	1000				Input to case
	1000				Output to case
Switching Frequency		400		kHz	Fixed
Frequency Synchronization	400		500	kHz	See note.
MTBF					>1 Mhrs to MIL-HDBK-217F at 25 °C, GF See table below
Remote On/Off	On = >3.5 V or open circuit; Off = <1.8 V				
Rth Case - Ambient		7.12		°C/W	

Note: Control signal TTL 0-5 VDC square wave. The trigger is the falling edge.

MTBF

Model	25 °C GB	40 °C GF
MTC5028S3V3	1,754,739	269,617
MTC5028S05	2,160,519	357,885
MTC5028S12	2,105,612	351,150
MTC5028S15	2,086,654	345,227
MTC5028S28	1,894,824	290,456

Environmental

Characteristic	Minimum	Typical	Maximum	Units	Notes & Conditions
Operating Temperature	-55		100	°C	Baseplate temperature. Start up is at -55 °C. Full specification achievable at -40 °C
Storage Temperature	-60		125	°C	
Humidity			95	%	Relative humidity, MIL-STD-810F Method 507.4
Salt Atmosphere			48	Hrs	MIL-STD 810F Method 509.4
Altitude			70000	Ft	MIL-STD 810F Method 500.4
Shock			75	g	MIL-STD 810F Method 516.5
Vibration	15		2000	Hz	MIL-STD 810F Method 514.5, table 514.5-VIII
Bump			40	g	2000 bumps in each axis MIL-STD 810F Method 516.5

Electromagnetic Compatibility

EMC	Standard	Test Level	Criteria	Notes & Conditions
Conducted Emissions	MIL-STD-461E/F	CE102		When used in conjunction with standard EMI filter, DSF and FSO series
	DEF-STAN 59-411	DCE01/DCE02		
	EN55022	Class B		
Immunity	MIL-STD-1275A-D	Spikes	±250 V for 100 µs	When used in conjunction with standard surge protection module, DSF and FSO series
		Surge	100 V for 50 ms (see note)	
		Ripple	14 VAC pk-pk	
	MIL-STD-704B-F		50 V for 10 ms	
Conducted Susceptibility	MIL-STD-461E/F	CS101, CS114, CS115, CS116		When used in conjunction with standard surge protection module, DSF and FSO series
	DEF-STAN 62-5 part 6 iss.5			

Note: 0.5 Ω source impedance

Synchronization

The internal switching frequency can be synchronized to an external source within the range 450 to 550 kHz. If two modules or more are synchronized, they will run at the highest frequency. Connect synchronization pins directly together.

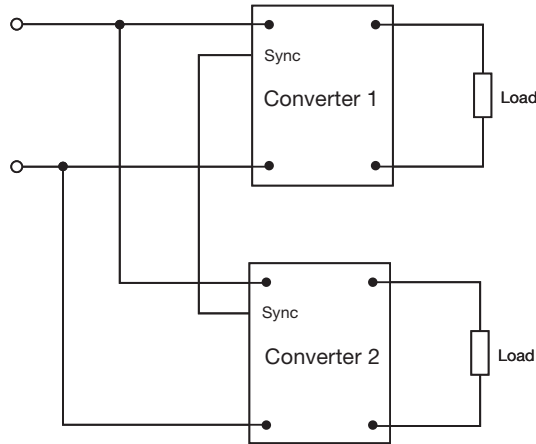

Figure 1. Synchronization Diagram

Thermal Warning

The thermal warning pin is an open collector signal with its emitter connected to -Vin. Transistor is off under normal conditions and is turned on when trip threshold is exceeded typically 105 °C. The output of the module can be optionally turned off under a high temperature condition by connecting the Thermal Warning (TW) pin directly to the Remote On/Off pin (Thermal Shutdown). The output will recover automatically when the case temperature is reduced.

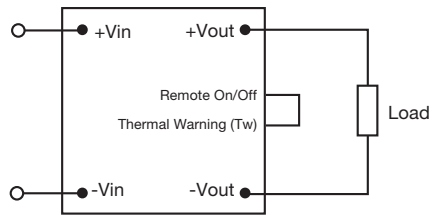

Figure 2. Thermal Shutdown Connection Diagram

Overload Protection

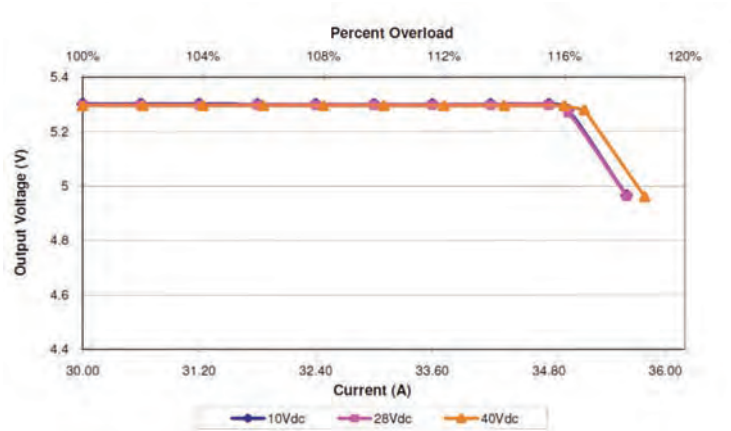

Figure 3. Over current Profile

After reaching the limit between 110% to 140% of Inom (current or power limit point), the output voltage will reduce down to 40-50% of nominal below which the unit will enter trip and restart mode. Automatic recovery when overload is removed.

Remote Sensing - Single Output Models Only

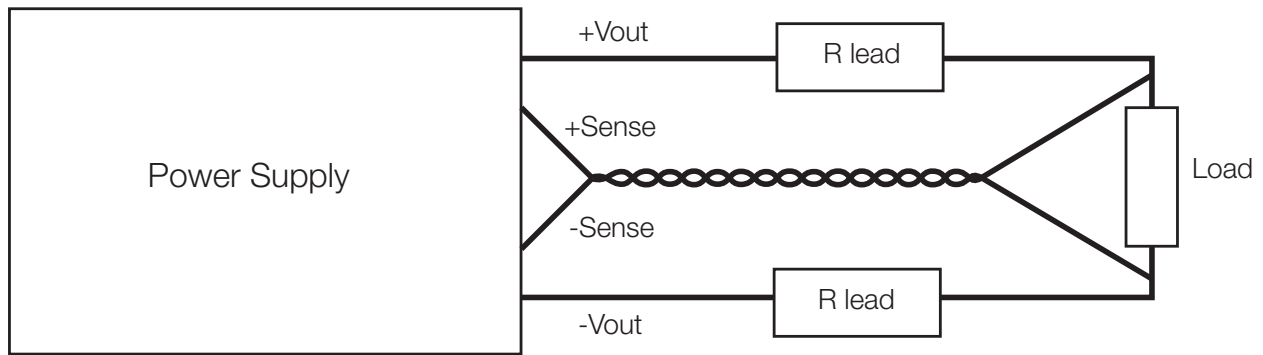

Figure 4. Remote Sense Connection Diagram

Notes.

1. To use the remote sense connect +Sense pin to +Vout and -Sense pin to -Vout.
2. When remote sense is not in use leave pins not connected or connected locally to ±Vout.

Output Voltage Adjustment

To trim the output voltage of the single output versions up or down, connect the trim resistor either between the trim pin and +sense for trimming-up or between trim pin and -sense for trimming-down. To trim the output voltage of the dual output versions up or down, connect the trim resistor either between the trim pin and +Vout for trimming up or between trim pin and -Vout for trimming down. The trimming output voltage range is ±10% on 3V3 output voltage and -20% to +10% rated output voltage on others. See diagram & table below.

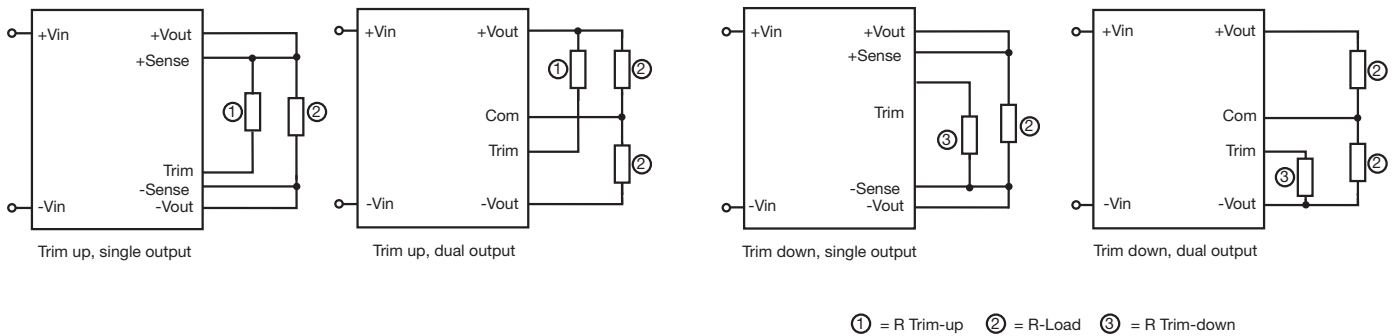

Figure 5. Trim up

Figure 6. Trim down

Trim up resistor=

$$R \text{ trim-up} = \left[\frac{A}{1 - \frac{V_{nom}}{V_{required}}} - C \right] \text{ k}\Omega$$

Trim down resistor=

$$R \text{ trim-down} = \left[\frac{B}{\frac{V_{nom}}{V_{required}} - 1} - C \right] \text{ k}\Omega$$

MTC35 & 50					
	S3V3	S05	S12	S15	S28
A	9.826	15	43.814	56.056	81.993
B	6	5	5.1	5.1	3.825
C	5.1	5.1	5.1	5.1	9.1

Redundant Configuration

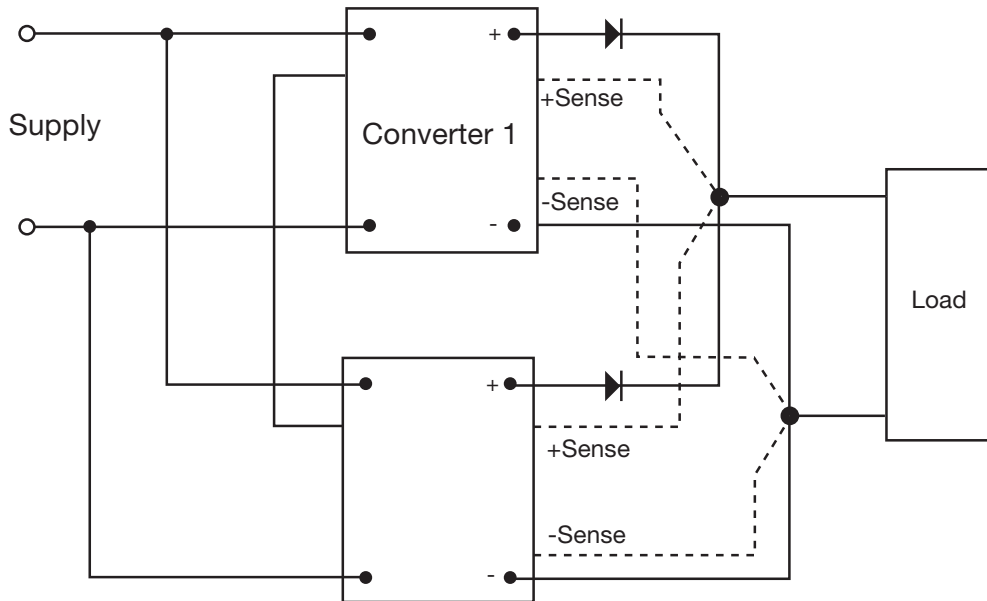
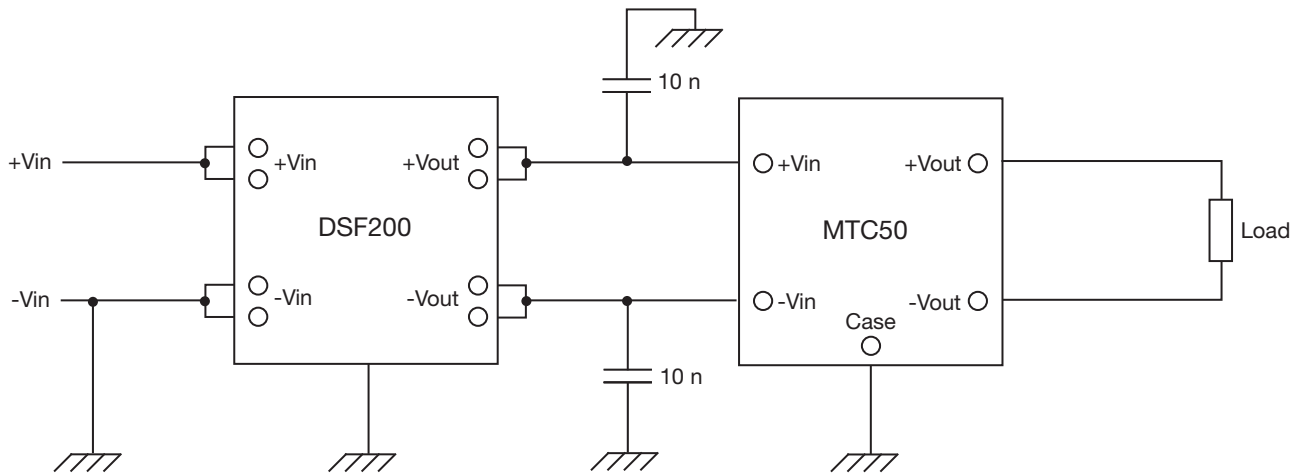
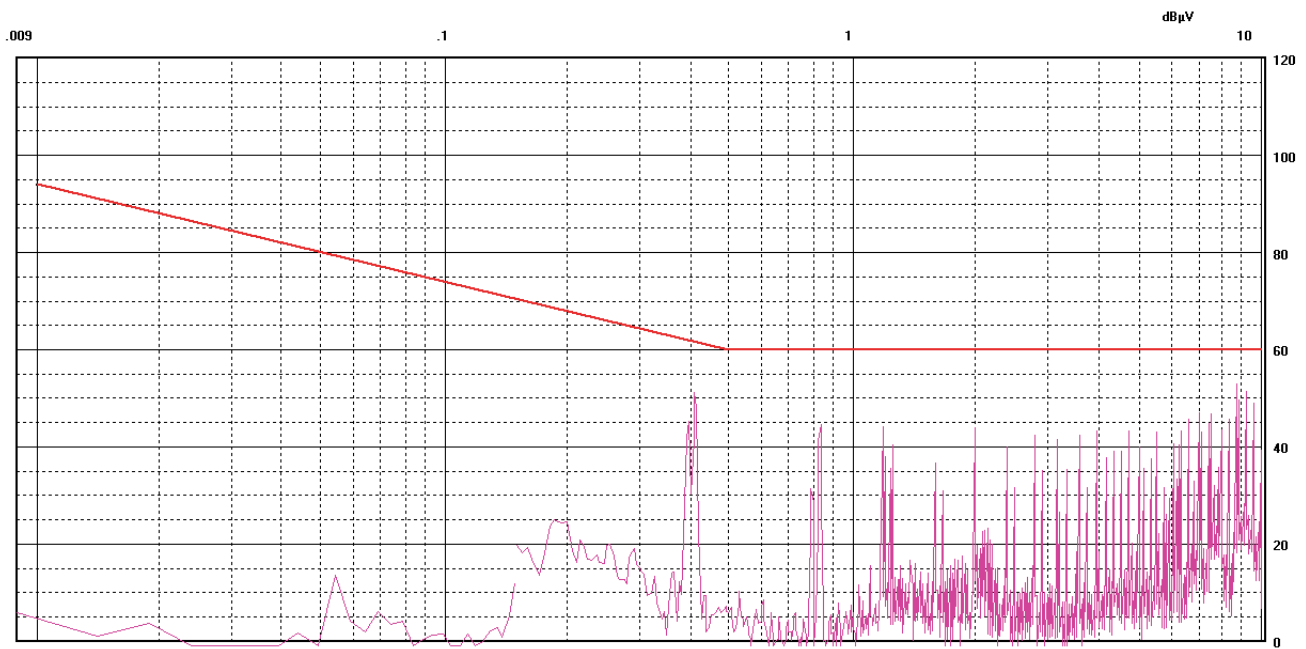

Figure 7 - Redundant configuration

EMC Connection Diagram and Performance Curve Examples



PMM 8000PLUS Name: TextPathlast1 Date: 20/08/10 Time: 09:54



Limit: M4461e Detector: Peak

MTC5028S12 12V @ 4.32A with small heatsink for load resistors, with filter and ground, with 10nF capacitors between input +/- and ground, heatsink connects to ground individually

Figure 8. MTC5028S12 connection diagram and conducted emissions test results

Efficiency - MTC35

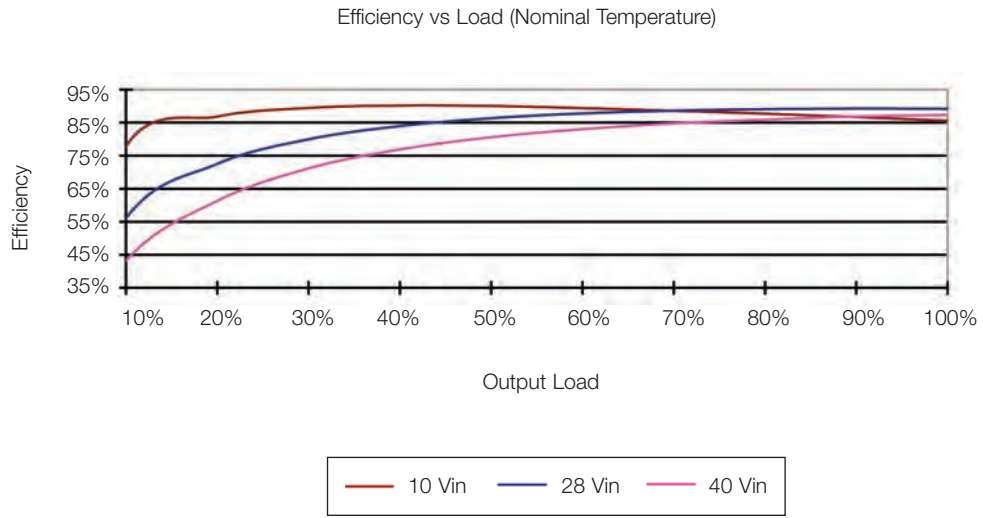

Figure 9. MTC3528S05

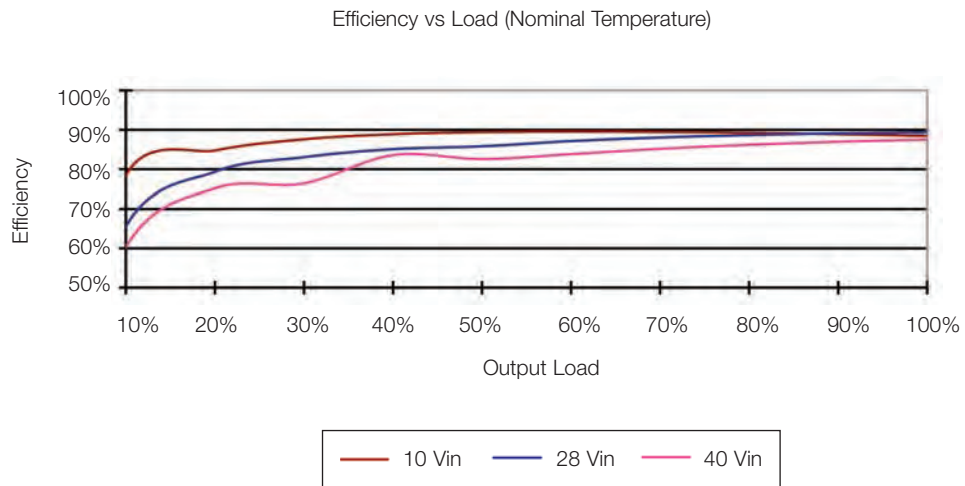

Figure 10. MTC3528S12

Efficiency - MTC50

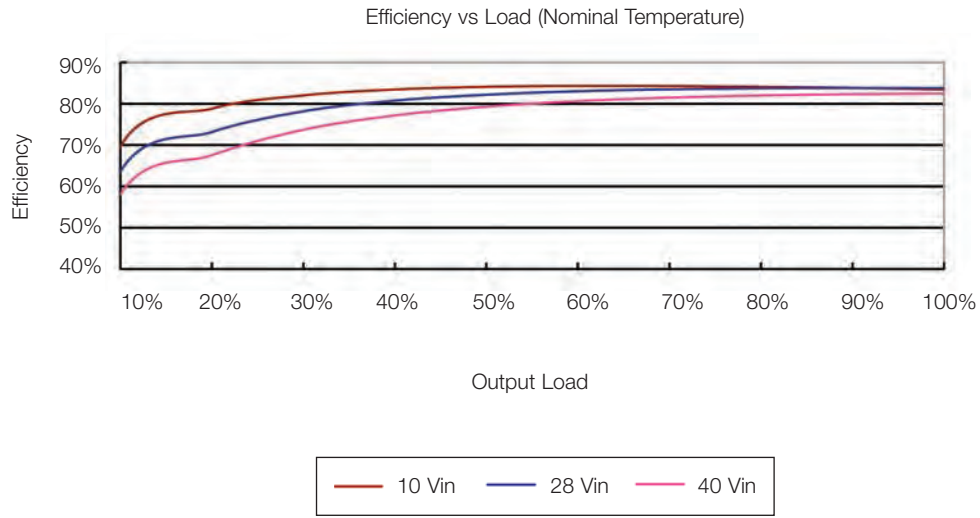

Figure 12. MTC5028S05

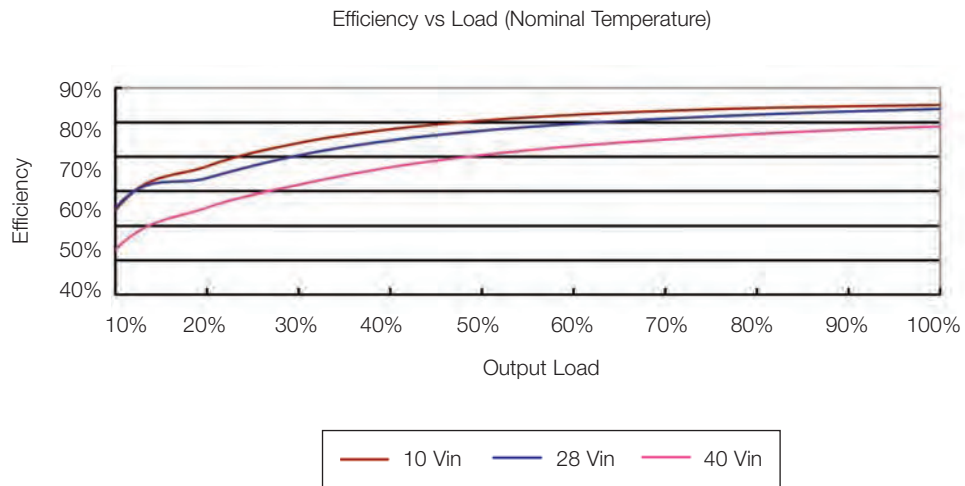

Figure 12. MTC5028S28

Start Up - MTC35

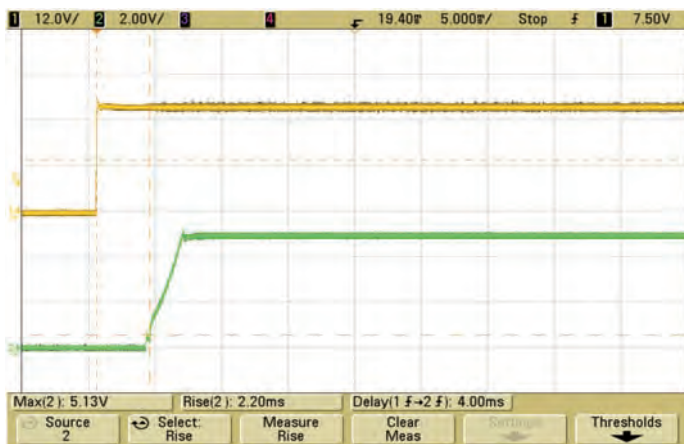

Figure 13. MTC3028S05 (25 °C) full resistive load - 4 ms

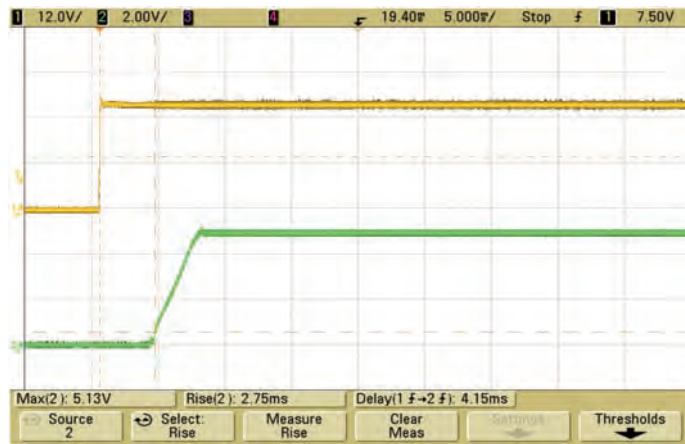

Figure 14. MTC3028S12 (25 °C) full resistive load - 4.15 ms

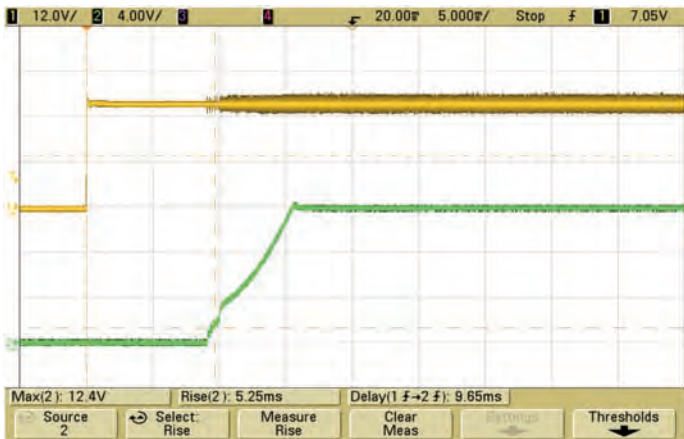

Figure 15. MTC7528S05 (25 °C) full resistive load and capacitor - 9.65 ms

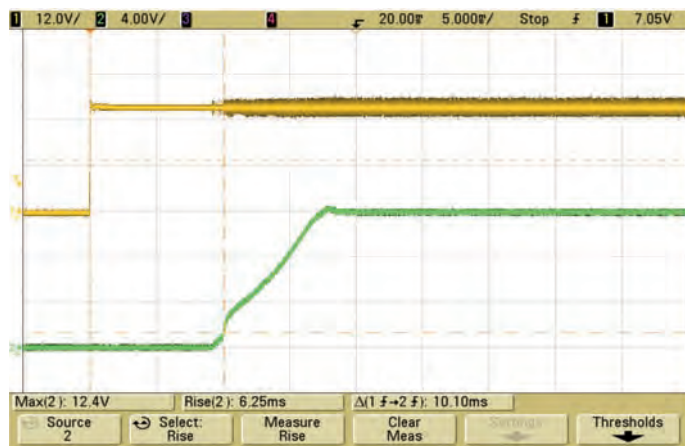

Figure 16. MTC7528S12 (25 °C) full resistive load and capacitor - 10.1 ms

Start Up - MTC50

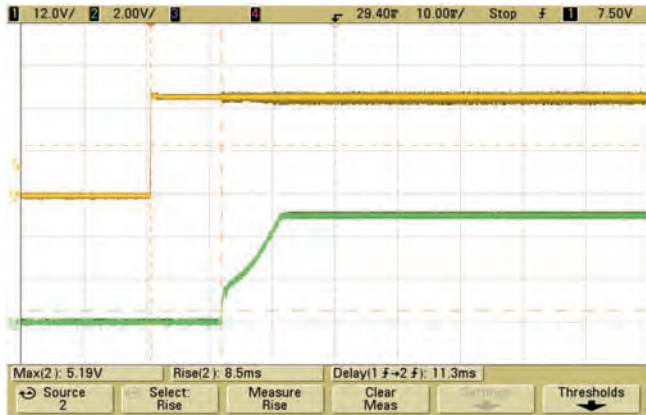

Figure 17. MTC5028S05 (25 °C) full resistive load - 11.3 ms

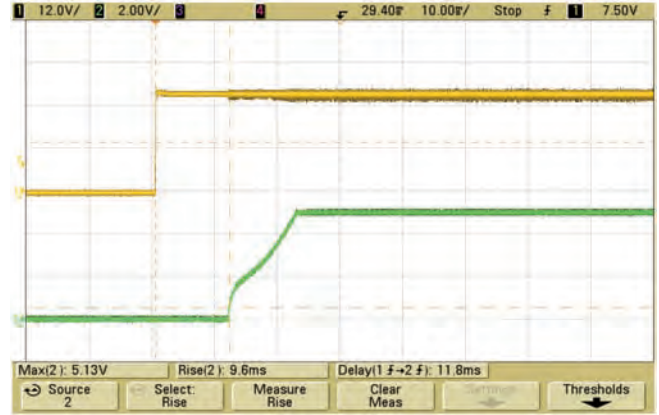

Figure 18. MTC5028S28 (25 °C) full resistive load - 11.85 ms

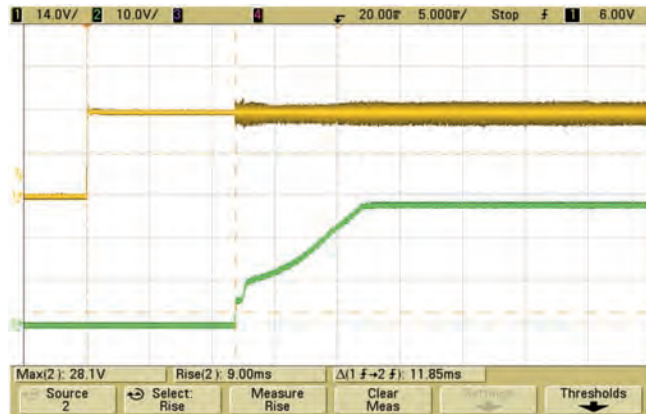

Figure 19. MTC5028S05 (25 °C) full resistive load and capacitor - 11.8 ms

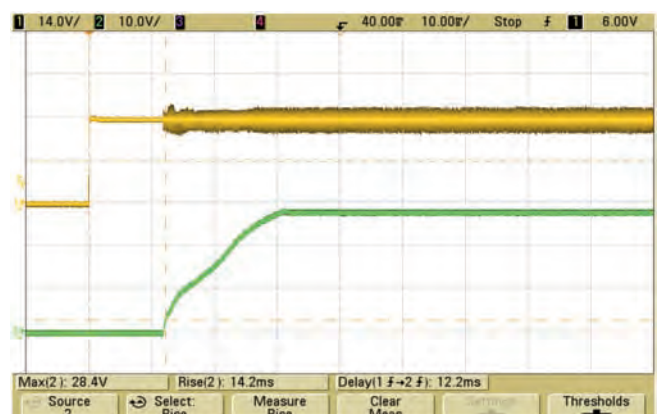
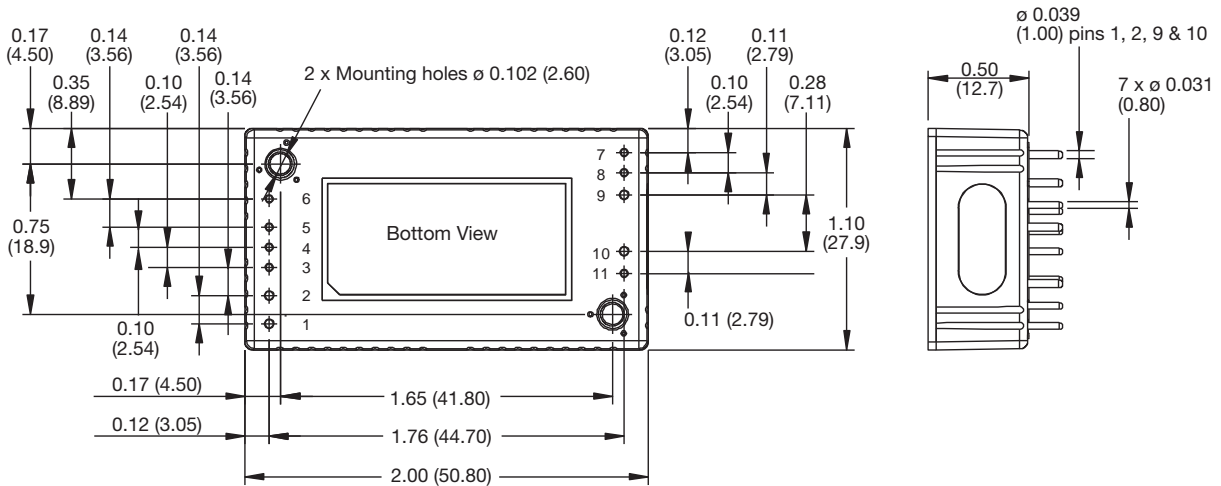

Figure 20. MTC5028S28 (25 °C) full resistive load and capacitor - 12.2 ms

Mechanical Details

MTC35



Notes

- Dimensions are in inches (mm)
- Tolerance: ± 0.02 inches (± 0.5 mm)
- Weight: 0.07 lb (35 g) approx

4. Materials & Finish:

Pin - Material: Copper
 Finish: Nickel plated 2.5 μ m Ni and gold plated 0.3 μ m Au.

Mounting Hole Diameter - 0.10 (2.7) clearance hole

Baseplate - Material: Aluminium

Case - Material: Non-conductive plastic

Pin Connections			
Pin	Single Output	Pin	Single Output
1	+Vin	7	Trim
2	-Vin	8	-Sense
3	Thermal Warning (TW)	9	-Vout
4	Synchronization	10	+Vout
5	Inhibit (Inh.)	11	+Sense
6	Case		

MTC50

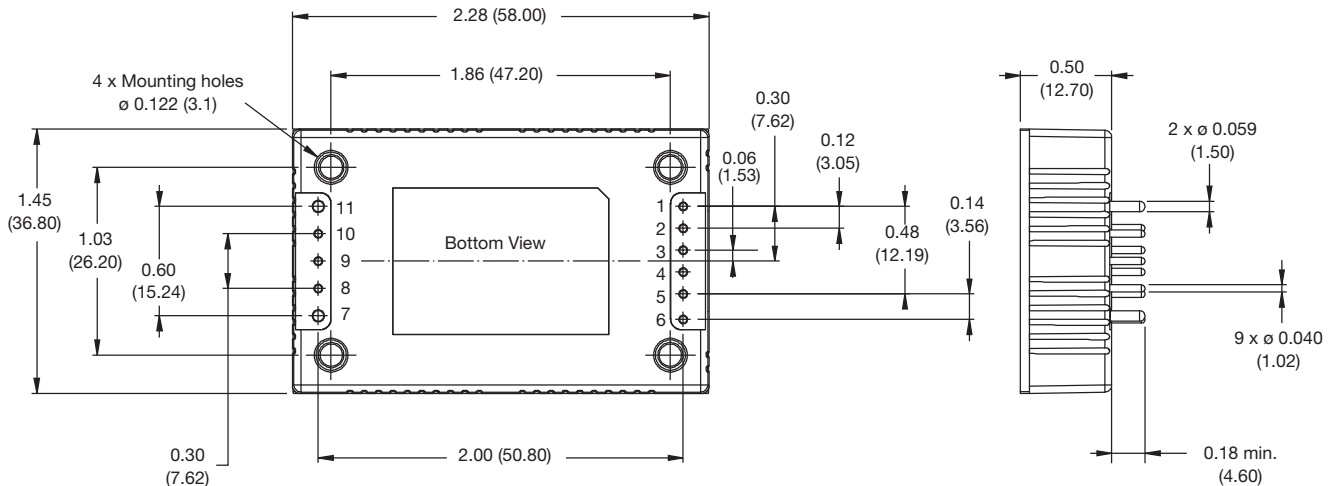

Notes

- Dimensions are in inches (mm)
- Tolerance: ± 0.02 inches (± 0.5 mm)
- Weight: 0.14 lb (62 g) approx

4. Materials & Finish:

Pin - Material: Copper
 Finish: Nickel plated 2.5 μ m Ni and gold plated 0.3 μ m Au.

Mounting Hole Diameter - 0.126 (3.2) clearance hole

Baseplate - Material: Aluminium

Case - Material: Non-conductive plastic

Pin Connections			
Pin	Single Output	Pin	Single Output
1	+Vin	7	-Vout
2	Remote On/Off	8	-Sense
3	Synchronization	9	Trim
4	Thermal Warning (TW)	10	+Sense
5	-Vin	11	+Vout
6	Case		

MTC75 & 150



- COTS Component for Defense & Avionics Applications
- Single & Dual Output Models
- Environmental Performance to MIL-STD 810
- 10 to 50 VDC Transient Input Range
- 10 to 40 VDC Steady State Input Range
- 150 W Max Output Power
- -55 °C to 100 °C Operation
- Cooling Plates and Mounting Holes for Easy Integration
- Synchronous Rectification on Low Voltage Outputs
- MIL-STD 461 and DEF-STAN 59-11
- MIL-STD 1275 and DEF-STAN 61-5
- Frequency Synchronization
- Thermal Warning Signal

The MTC75 & 150 are COTS DC-DC converters developed specifically for the defense and avionics market. These products have full military specifications while offering the short lead-times and cost benefits of a COTS component.

The products offer excellent size, efficiency and EMC performance and the input range is designed to provide short term operation over 10-50 VDC to enable the converter to work at full power through the dips and surges commonly seen in vehicle and aircraft applications.

Comprehensive control functions such as voltage trim, remote sense, remote on/off and frequency synchronization to an external source are standard features. The MTC75 & 150 contain an over temperature warning signal that gives user control over the temperature shutdown function of the converter.

When used in conjunction with the DSF and FSO input filter module the MTC75 & 150 are compliant to MIL-STD 461F CE/CS, MIL-STD1275A-D and MIL-STD 704B-F as well as DEF-STAN-59-411 and DEF-STAN 61-5 part 6 issue 5.



T H E X P E R T S I N P O W E R

Input Characteristics

Characteristic	Minimum	Typical	Maximum	Units	Notes & Conditions
Input Voltage	10	28	40	VDC	Continuous
Transient Input Voltage Range	10		50	VDC	50 VDC for 100 ms
UVLO Turn On	9.4			VDC	
UVLO Turn Off			8.7	VDC	
Input Current					See models and ratings table, typical and measured at 28 VDC input
Inhibited Input Current			4	mA	
Inrush Current			40	A	Peak value
Input Reverse Voltage Protection					External components required

Output Characteristics

Characteristic	Minimum	Typical	Maximum	Units	Notes & Conditions
Output Voltage				VDC	See models and ratings table for details
Output Voltage Adjustment	-20		+10	%	-10% min voltage trim for 3V3 version
Output Current				A	See models and ratings table for details
Output Set Tolerance			±1.5	%	
Minimum Load	Single O/P	0		A	No minimum load required
	Dual O/P	5		%	See note 3
Ripple & Noise	Vout ≤5V		50	mV	Pk-pk at 100% load and 20 MHz bandwidth
	Vout >5V		100		
Overshoot Protection	120		140	%	Vout nominal
Overload Protection	110		140	%	At Vin nominal, see figure 3
Short Circuit Protection					Output turns off until the short is removed
Overtemperature Protection			105	°C	Baseplate Temperature
Remote Sense			10	%	Total voltage compensation. Includes Vtrim. See fig 4.
Load Regulation	Single O/P	1		%	Vout nominal
	Dual O/P	2			
Cross Regulation			±4	%	Dual outputs only. See note 3.
Transient Response			±4	%	Recovery within 1% in less than 500µs for a 50% load change at 0.1A/µs
Line Regulation			±1	%	Vout nominal at 10-40 Vin
Maximum Output Capacitance			300 x Iout max	µF	For start up within 100 ms
Start Up Time			100	ms	
Start Up Rise Time			20	ms	
Temperature Coefficient			0.3	%/°C	

Models & Ratings

Output Power	Output Voltage	Output Current	Input Current ⁽¹⁾		Efficiency ⁽¹⁾	Model Number
			No Load	Full Load		
66 W	3.3 VDC	20.00 A	120 mA	2.87 A	82%	MTC7528S3V3
75 W	5.0 VDC	15.00 A	130 mA	3.19 A	84%	MTC7528S05
75 W	12.0 VDC	6.25 A	60 mA	3.19 A	84%	MTC7528S12
75 W	15.0 VDC	5.00 A	40 mA	3.19 A	84%	MTC7528S15
75 W	28.0 VDC	2.70 A	75 mA	3.23 A	83%	MTC7528S28
75 W	±12.0 VDC	±3.13 A ⁽⁴⁾	220 mA	3.23 A	83%	MTC7528D12 ⁽³⁾
75 W	±15.0 VDC	±2.50 A ⁽⁴⁾	230 mA	3.27 A	82%	MTC7528D15 ⁽³⁾
132 W	3.3 VDC	40.00 A	120 mA	5.82 A	81%	MTC15028S3V3
150 W	5.0 VDC	30.00 A	147 mA	6.38 A	84%	MTC15028S05
150 W	12.0 VDC	12.50 A	70 mA	6.38 A	84%	MTC15028S12
150 W	15.0 VDC	10.00 A	75 mA	6.30 A	86%	MTC15028S15
150 W	28.0 VDC	5.35 A	170 mA	6.30 A	86%	MTC15028S28
150 W	±12.0 VDC	±6.25 A ⁽⁴⁾	250 mA	6.38 A	84%	MTC15028D12 ⁽³⁾
150 W	±15.0 VDC	±5.00 A ⁽⁴⁾	275 mA	6.31 A	85%	MTC15028D15 ⁽³⁾

Note: 1. Typical and measured at 28 V input
2. Total of voltage trim and remote sense is +10% max.

3. Minimum load of 5% required on one output for ±4% regulation on the other.
4. Each output can deliver 70% of the combined current when other output delivers between 5% and 30%.

General Specifications

Characteristic	Minimum	Typical	Maximum	Units	Notes & Conditions
Efficiency		84		%	See models table and performance graphs (fig. 28-34)
Isolation Voltage	1500			VDC	Input to output
	1000				Input to case
	1000				Output to case
Switching Frequency		450		kHz	Fixed
Frequency Synchronization	450		550	kHz	See note.
MTBF					>1 Mhrs to MIL-HDBK-217F at 25 °C, GF See table below
Remote On/Off	On = >3.5 V or open circuit; Off = <1.8 V				
Rth Case - Ambient		7.12		°C/W	

Note: Control signal TTL 0-5 VDC square wave. The trigger is the falling edge.

MTBF

Model	25 °C GF	40 °C GF
MTC15028S3V3	1,078,632	158,847
MTC15028S05	1,162,633	172,796
MTC15028S12	1,316,925	196,186
MTC15028S15	1,322,349	199,100
MTC15028S28	1,367,231	209,016
MTC15028D12	1,498,551	264,559
MTC15028D15	1,442,550	258,790

Note: 20 °C and 40 °C are assumed to be baseplate temperatures

Environmental

Characteristic	Minimum	Typical	Maximum	Units	Notes & Conditions
Operating Temperature	-55		100	°C	Baseplate temperature. Start up is at -55 °C. Full specification achievable at -40 °C
Storage Temperature	-60		125	°C	
Humidity			95	%	Relative humidity, MIL-STD-810F Method 507.4
Salt Atmosphere			48	Hrs	MIL-STD 810F Method 509.4
Altitude			70000	Ft	MIL-STD 810F Method 500.4
Shock			75	g	MIL-STD 810F Method 516.5
Vibration	15		2000	Hz	MIL-STD 810F Method 514.5, table 514.5-VIII
Bump			40	g	2000 bumps in each axis MIL-STD 810F Method 516.5

Electromagnetic Compatibility

EMC	Standard	Test Level	Criteria	Notes & Conditions
Conducted Emissions	MIL-STD-461E/F	CE102		When used in conjunction with standard EMI filter, DSF and FSO series
	DEF-STAN 59-411	DCE01/DCE02		
	EN55022	Class B		
Immunity	MIL-STD-1275A-D	Spikes	±250 V for 100 µs	When used in conjunction with standard surge protection module, DSF and FSO series
		Surge	100 V for 50 ms (see note)	
		Ripple	14 VAC pk-pk	
	MIL-STD-704B-F		50 V for 10 ms	
Conducted Susceptibility	MIL-STD-461E/F	CS101, CS114, CS115, CS116		When used in conjunction with standard surge protection module, DSF and FSO series
	DEF-STAN 62-5 part 6 iss.5			

Note: 0.5 Ω source impedance

Synchronization

The internal switching frequency can be synchronized to an external source within the range 450 to 550 kHz. If two modules or more are synchronized, they will run at the highest frequency. Connect synchronization pins directly together.

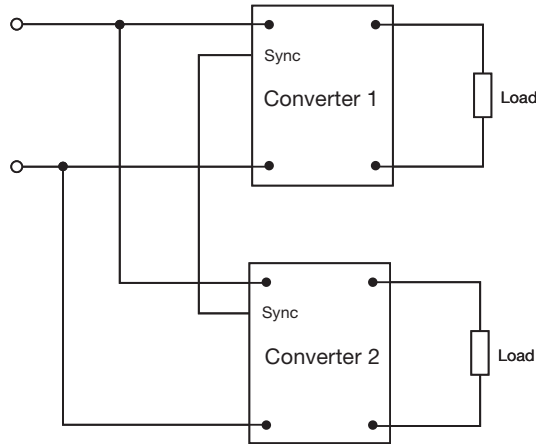

Figure 1. Synchronization Diagram

Thermal Warning

The thermal warning pin is an open collector signal with its emitter connected to -Vin. Transistor is off under normal conditions and is turned on when trip threshold is exceeded typically 105 °C. The output of the module can be optionally turned off under a high temperature condition by connecting the Thermal Warning (TW) pin directly to the Remote On/Off pin (Thermal Shutdown). The output will recover automatically when the case temperature is reduced.

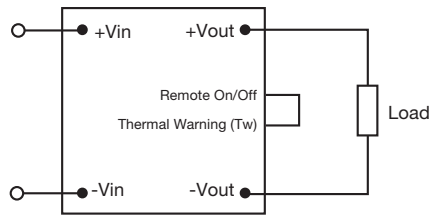

Figure 2. Thermal Shutdown Connection Diagram

Overload Protection

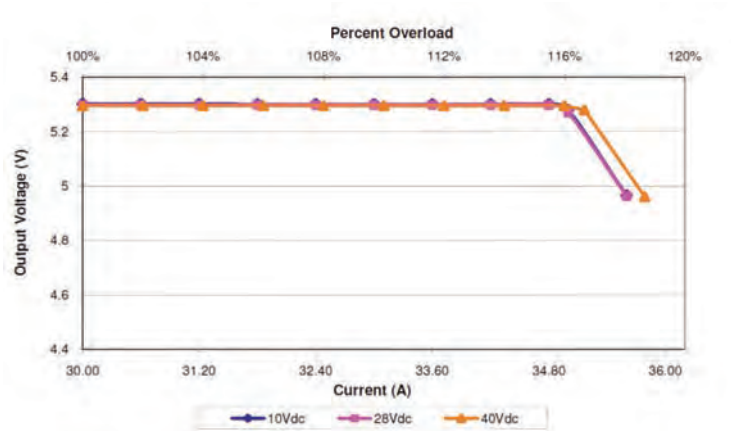

Figure 3. Over current Profile

After reaching the limit between 110% to 140% of Inom (current or power limit point), the output voltage will reduce and the unit will enter trip and restart mode. Automatic recovery when overload is removed.

Remote Sensing - Single Output Models Only

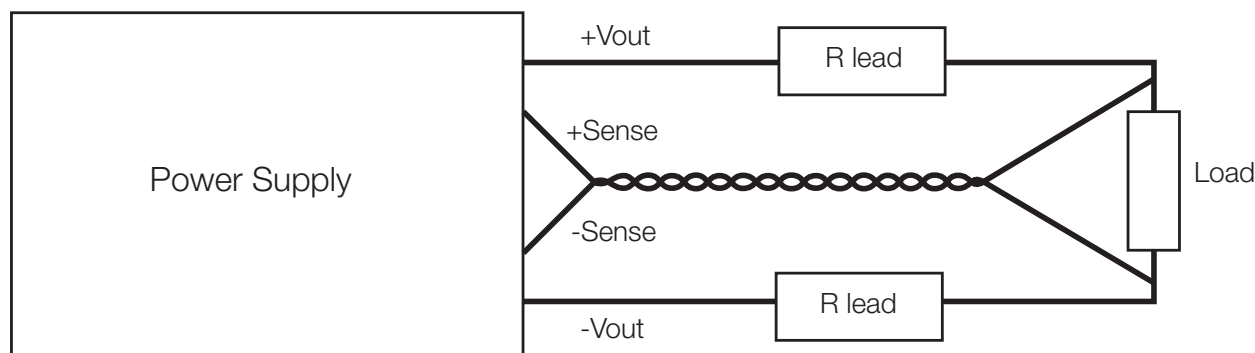

Figure 4. Remote Sense Connection Diagram

Notes.

1. To use the remote sense connect +Sense pin to +Vout and -Sense pin to -Vout.
2. When remote sense is not in use leave pins not connected or connected locally to ±Vout.

Output Voltage Adjustment

To trim the output voltage of the single output versions up or down, connect the trim resistor either between the trim pin and +sense for trimming-up or between trim pin and -sense for trimming-down. To trim the output voltage of the dual output versions up or down, connect the trim resistor either between the trim pin and +Vout for trimming up or between trim pin and -Vout for trimming down. The trimming output voltage range is ±10% on 3V3 output voltage and -20% to +10% rated output voltage on others. See diagram & table below.

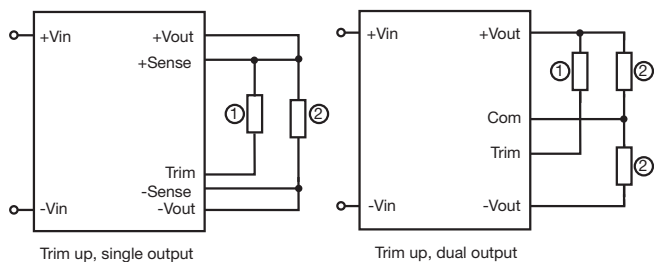

Figure 5. Trim up

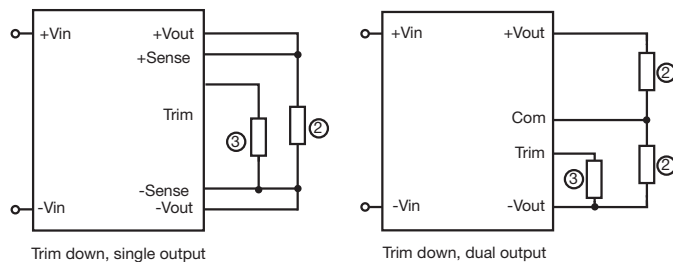

Figure 6. Trim down

① = R Trim-up ② = R-Load ③ = R Trim-down

Trim up resistor=

$$R \text{ trim-up} = \left[\frac{A}{1 - \frac{V_{nom}}{V_{required}}} - C \right] \text{ k}\Omega$$

Trim down resistor=

$$R \text{ trim-down} = \left[\frac{B}{\frac{V_{nom}}{V_{required}} - 1} - C \right] \text{ k}\Omega$$

	S3V3	S05	S12	S15	S28	D12	D15
A	9.826	15	21.907	28.028	54.622	46.446	58.524
B	6	5	2.55	2.55	2.55	2.55	2.55
C	5.1	5.1	5.1	5.1	9.1	9.1	9.1

Parallel Configuration - Single Output Models Only

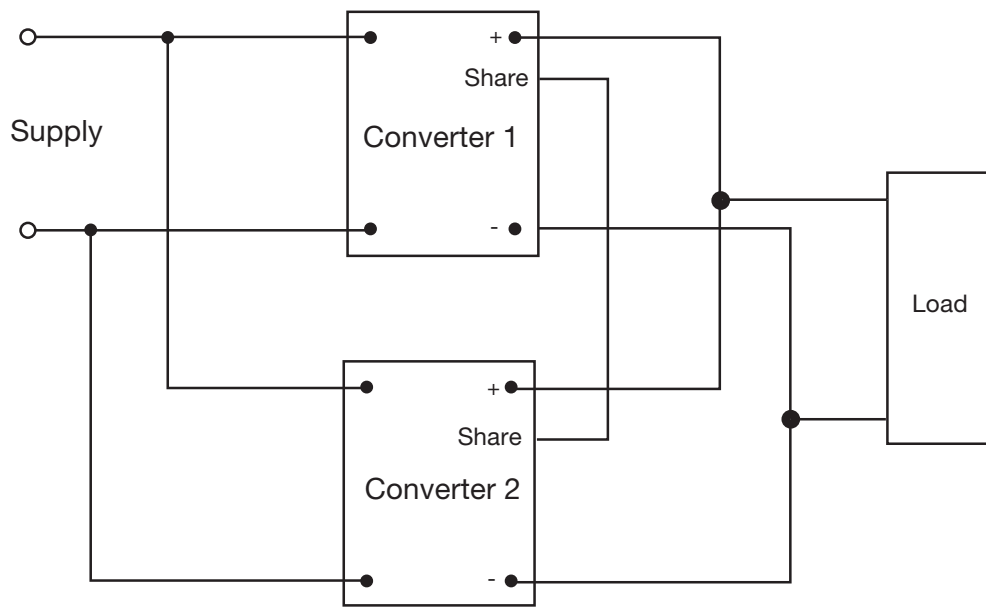

Figure 7. Parallel configuration for current sharing

Notes.

Up to 4 converters to share within 90% max power.

Redundant Configuration

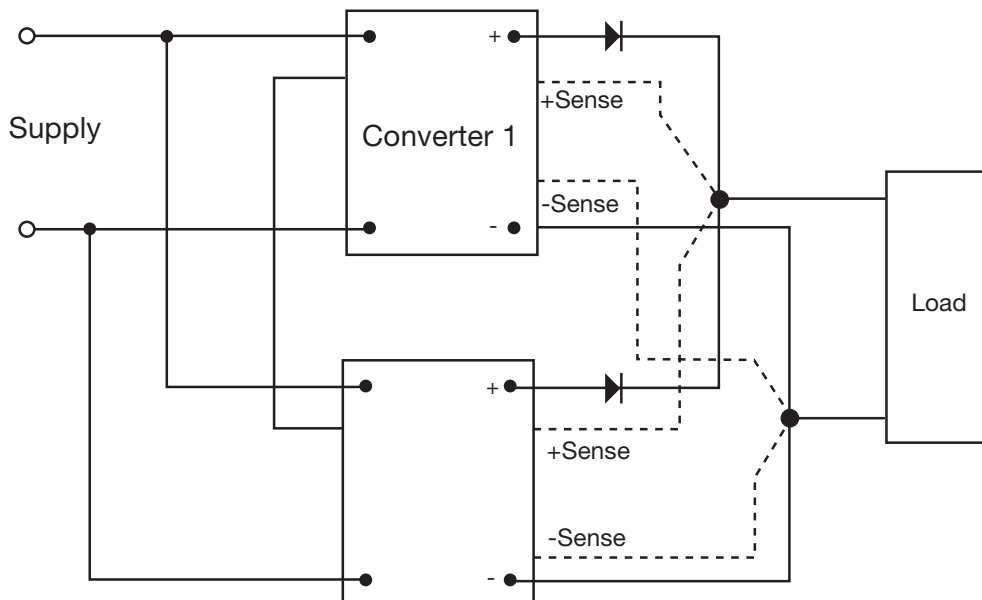

Figure 8 - Redundant configuration

Derating Curves

The operating case temperature range of MTC75 & 150 series is -40 °C to +100 °C (start up at -55 °C). When operating the MTC series, proper derating or conduction cooling is required. The maximum case temperature under any operating condition should not exceed 100 °C.

Power Dissipated vs Ambient Temperature and Air Flow

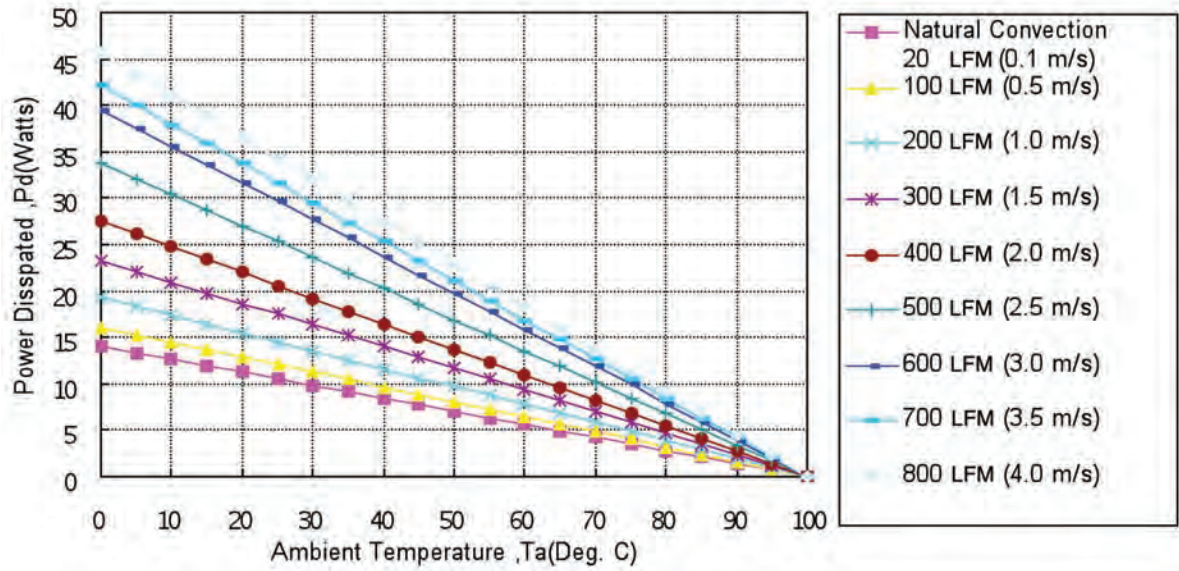

Figure 9. Derating curve of MTC75 & 150 series without heatsink

Example

The minimum airflow required for part number MTC7528S12 operating at nominal line, an output current of 6.25 A and a maximum ambient temperature of 40 °C can be determined using the formula below

Solution:

Determine Power dissipation (Pd): $Pd = Pi - Po = Po (1/\eta)$
 $Pd = 12 \times 6.25 \times (1-0.84) / 0.84 = 14.29$

Determine Airflow: Given: Pd = 14.29 W and Ta = 40 °C

Check above Power derating curve: Minimum airflow = 400 LFM (2.0 m/s)

Verification: Maximum temperature rise $\Delta T = Pd \times Rca = 14.29 \times 3.64 = 52 \text{ °C}$

Maximum case temperature: $Tc = Ta + \Delta T = 9$

Where: Rca is thermal resistance from case to ambient.

Ta is ambient temperature and Tc is the case temperature.

Air Flow Rate	Typical Rca
Natural Convection	7.12 °C/W
20 LFM (0.1 ms)	6.21 °C/W
100 LFM (0.5 ms)	5.17 °C/W
200 LFM (1.0 ms)	4.29 °C/W
300 LFM (1.5 ms)	3.64 °C/W
400 LFM (2.0 ms)	2.96 °C/W
500 LFM (2.5 ms)	2.53 °C/W
600 LFM (3.0 ms)	2.37 °C/W
700 LFM (3.5 ms)	2.19 °C/W
800 LFM (4.0 ms)	2.19 °C/W

Thermal Resistance vs Air Flow

Derating Curves Continued

Power Dissipated vs Ambient Temperature and Air Flow with Transverse Heatsink (Part number ICH-HT5K91)

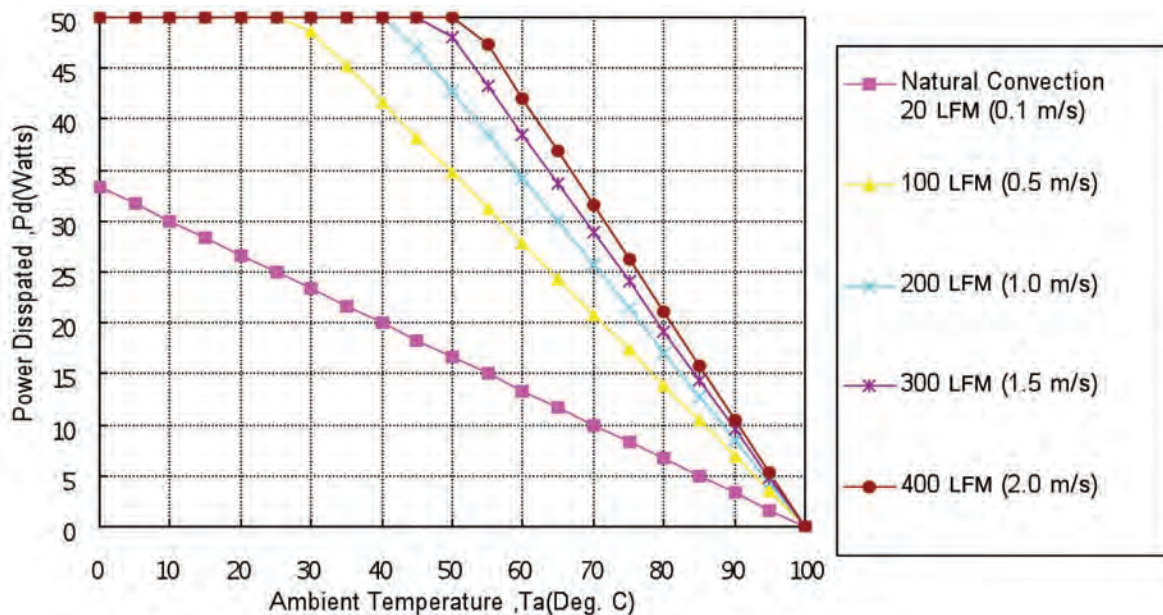

Figure 10. Derating curve of MTC75 & 150 series with heatsink

Example

What is the minimum airflow necessary for an MTC15028S12 operating at nominal line, an output current of 30 A, and a maximum ambient temperature of 40 °C?

Solution:

Determine Power dissipation (Pd): $P_d = P_i - P_o = P_o (1/\eta) / \eta$
 $P_d = 5 \times 30 \times (1-0.84) / 0.84 = 28.57 \text{ W}$

Determine Airflow: Given: $P_d = 28.57 \text{ W}$ and $T_a = 40 \text{ °C}$

Check above Power derating curve: Minimum airflow = 100 LFM (0.5 m/s)

Verification: Maximum temperature rise $\Delta T = P_d \times R_{ca} = 28.57 \times 1.44 = 41.14 \text{ °C}$

Maximum case temperature: $T_c = T_a + \Delta T = 81.14 \text{ °C} < 100 \text{ °C}$

Where: R_{ca} is thermal resistance from case to ambient.

T_a is ambient temperature and T_c is the case temperature.

Air Flow Rate	Typical R_{ca}
Natural Convection 20 LFM (0.1 ms)	3.0 °C/W
100 LFM (0.5 ms)	1.44 °C/W
200 LFM (1.0 ms)	1.17 °C/W
300 LFM (1.5 ms)	1.04 °C/W
400 LFM (2.0 ms)	0.95 °C/W

Thermal Resistance vs Air Flow

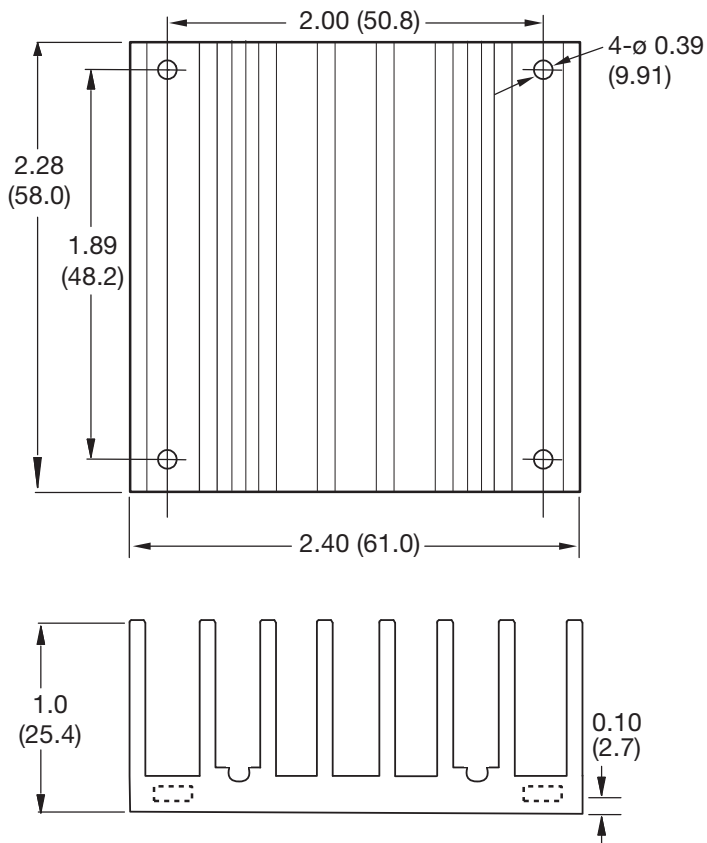

Rca:
3.00 °C/W (typ.), natural convection
1.44 °C/W (typ.), at 100 LFM
1.17 °C/W (typ.), at 200 LFM
1.04 °C/W (typ.), at 300 LFM
0.95 °C/W (typ.), at 400 LFM

Figure 11. Transverse Heat Sink (Part Number ICH-HTSK91)

EMC Connection Diagram and Performance Curve Examples

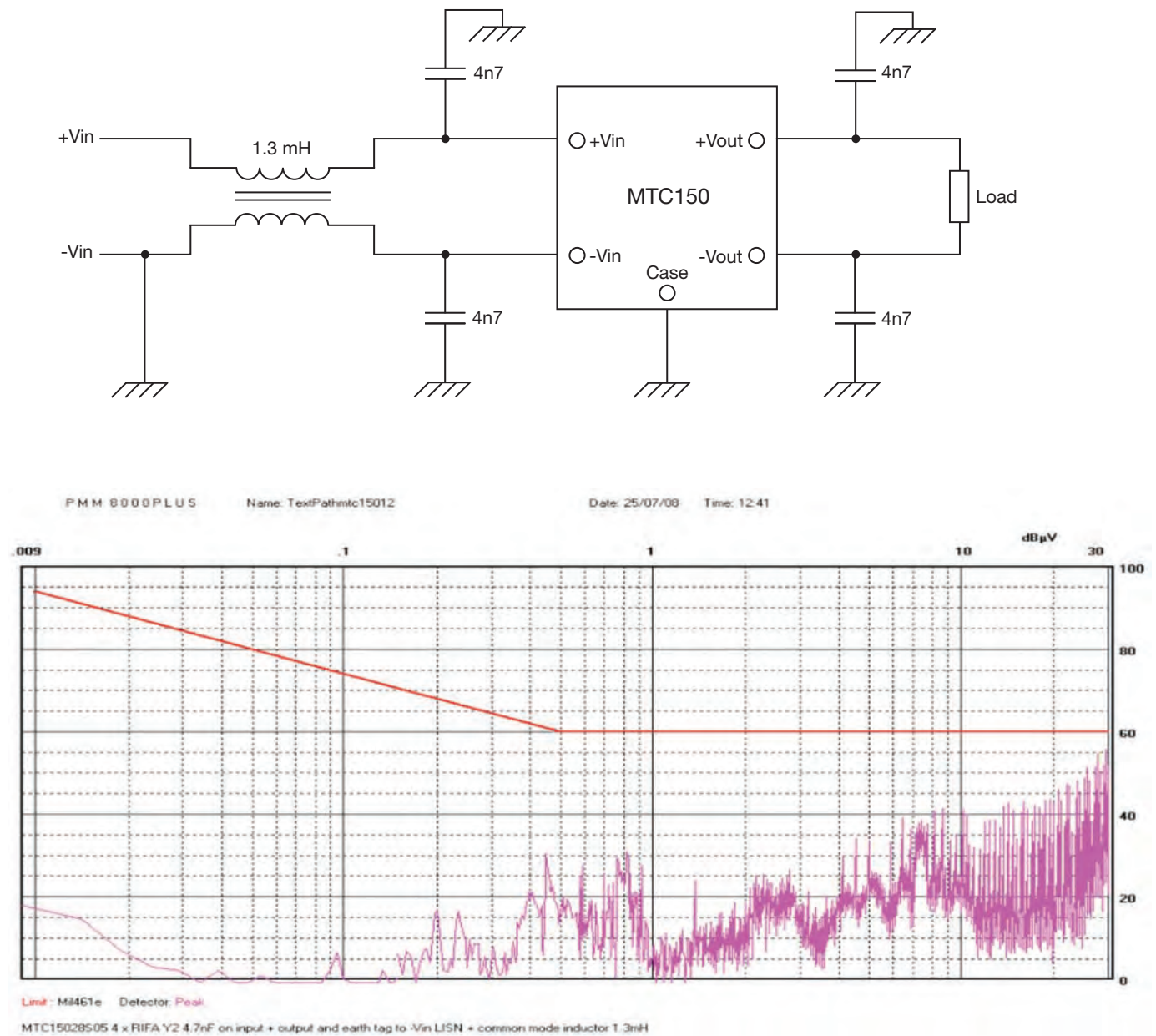

Figure 12. MTC15028S05 connection diagram and conducted emissions test results

EMC Connection Diagram and Performance Curve Examples

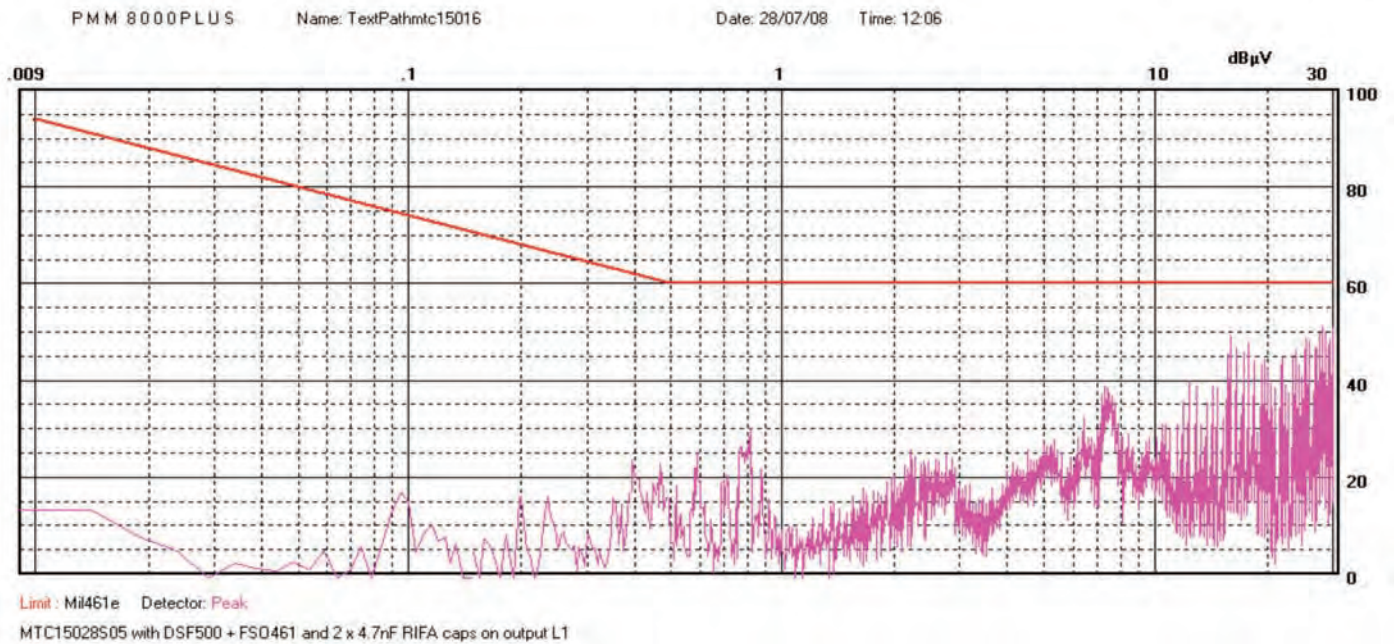
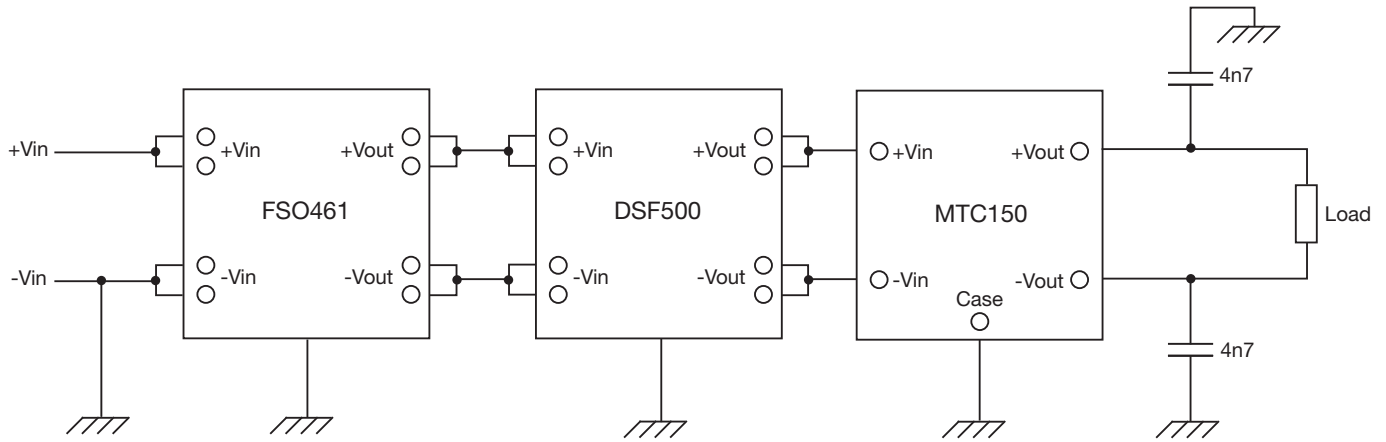

Figure 13. MTC15028S05 connection diagram and conducted emissions test results

EMC Connection Diagram and Performance Curve Examples

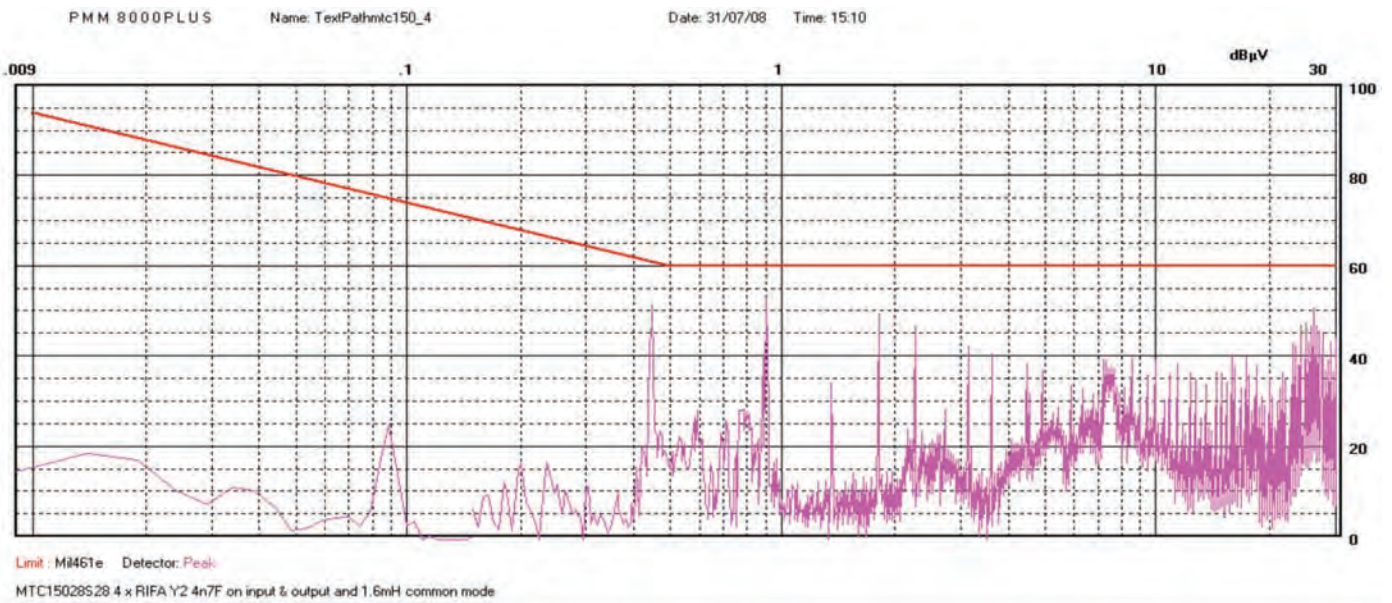
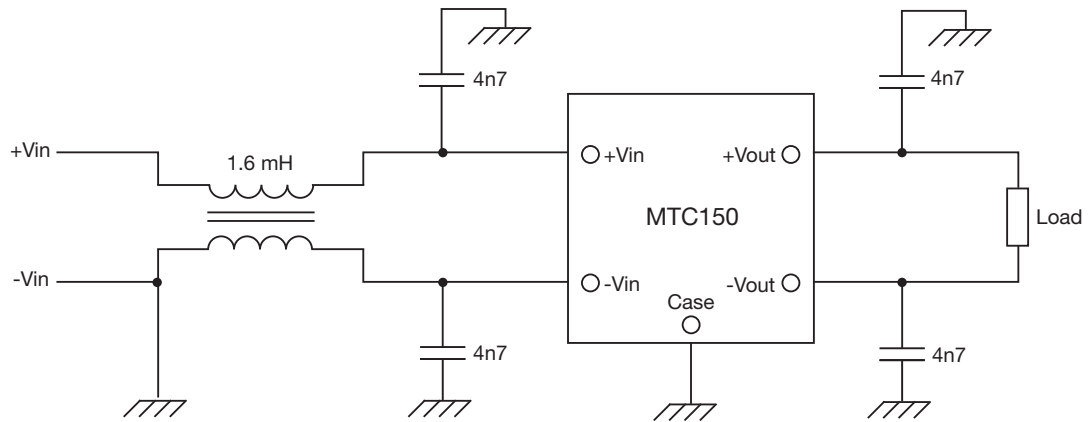

Figure 14. Connection Diagram MTC15028S28 connection diagram and conducted emissions test results

EMC Connection Diagram and Performance Curve Examples

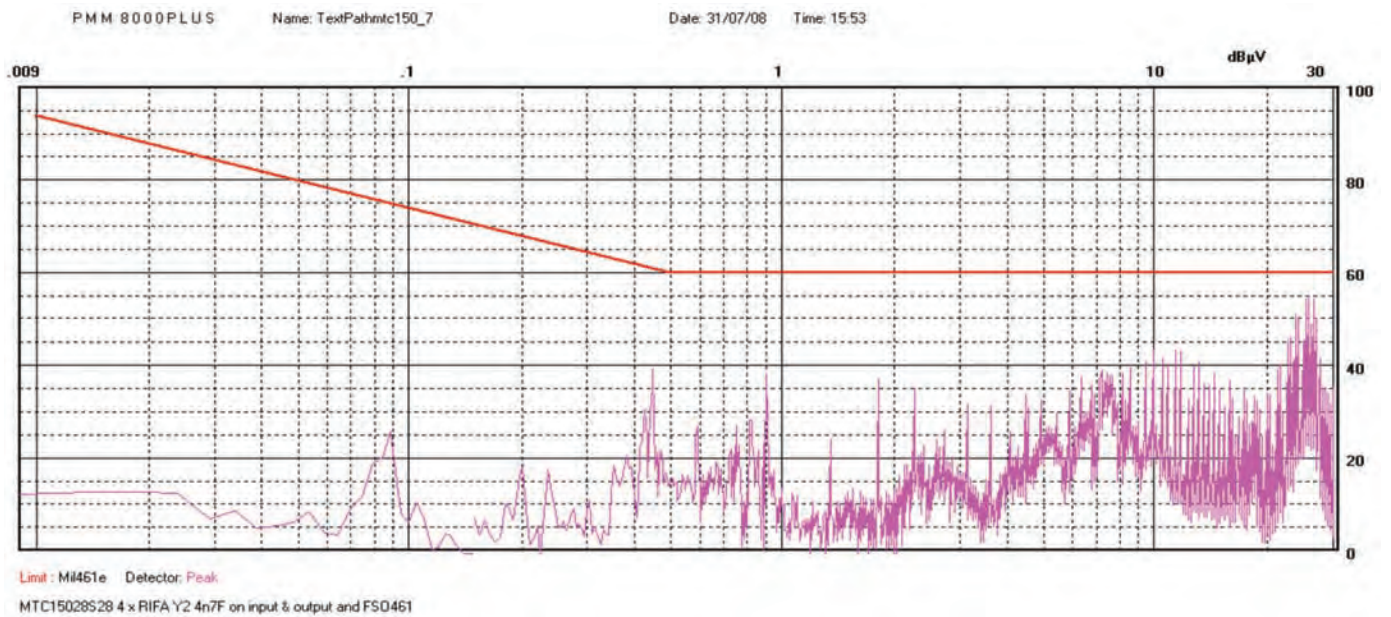
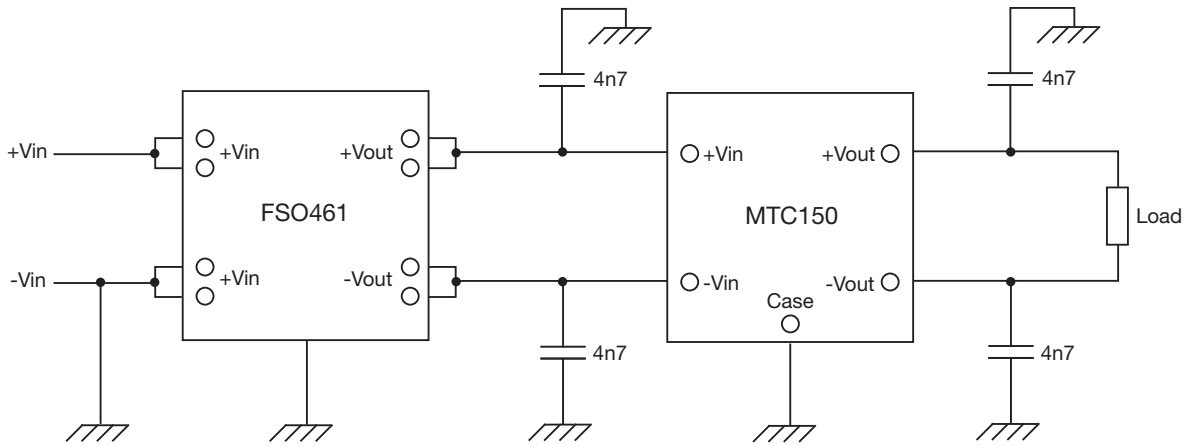

Figure 15. MTC15028S28 connection diagram and conducted emissions test results

Efficiency - MTC75

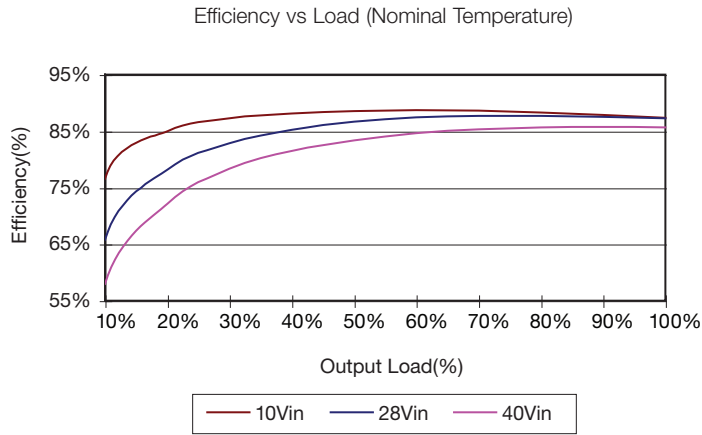

Figure 16. MTC7528S05

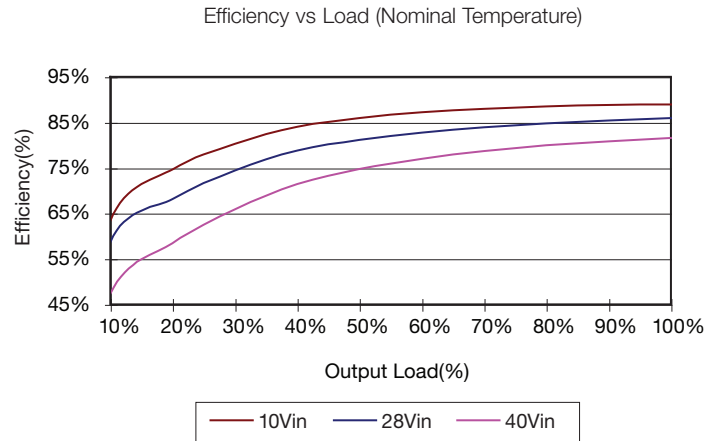

Figure 17. MTC7528S28

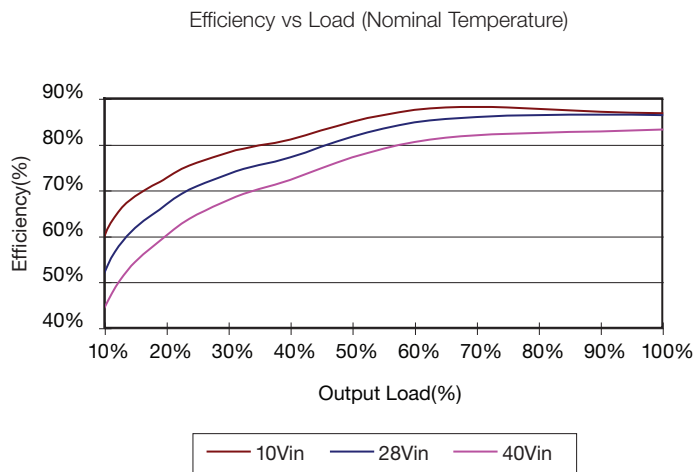

Figure 18. MTC7528D12

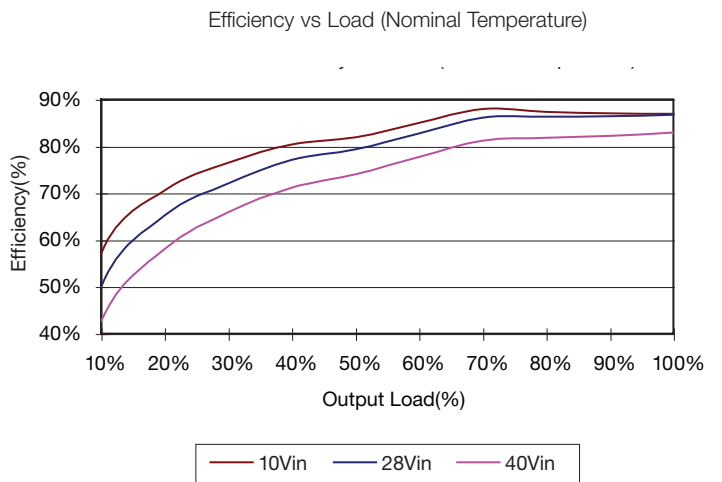

Figure 19. MTC7528D15

Efficiency - MTC150

Efficiency vs Load (Nominal Temperature)

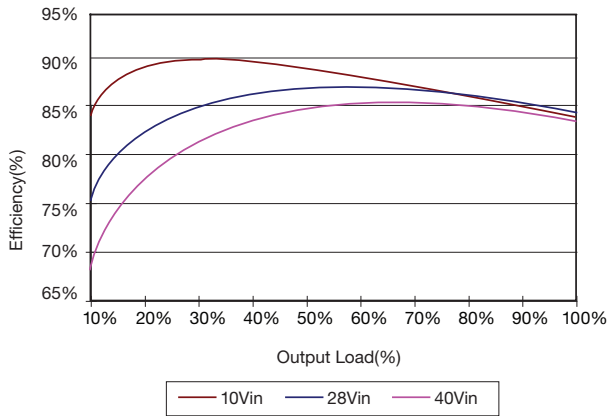

Figure 20. MTC15028S05

Efficiency vs Load (Nominal Temperature)

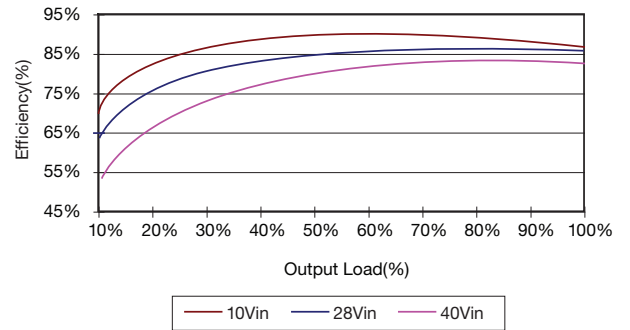

Figure 21. MTC15028S28

Efficiency vs Load (Nominal Temperature)

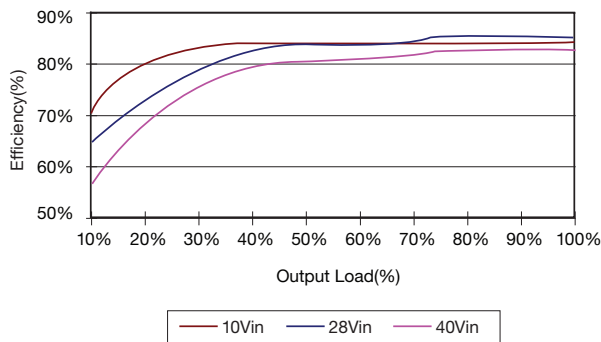

Figure 22. MTC15028D12

Efficiency vs Load (Nominal Temperature)

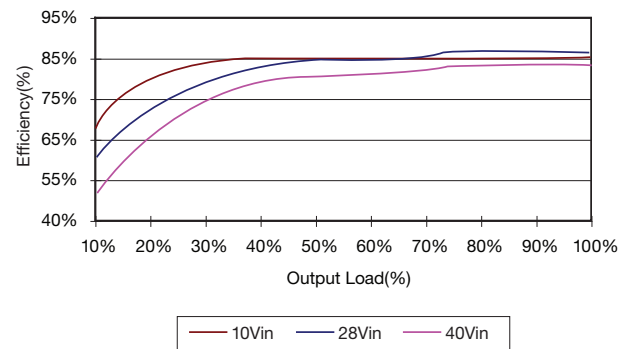

Figure 23. MTC15028D15

Start Up - MTC75

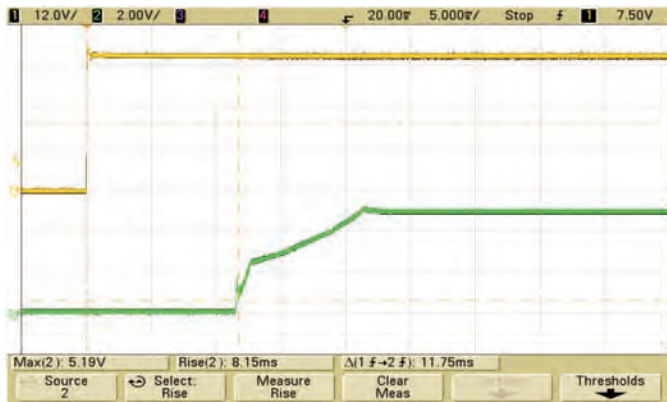

Figure 24. MTC7528S05 (25 °C) full resistive load - 11.9 ms

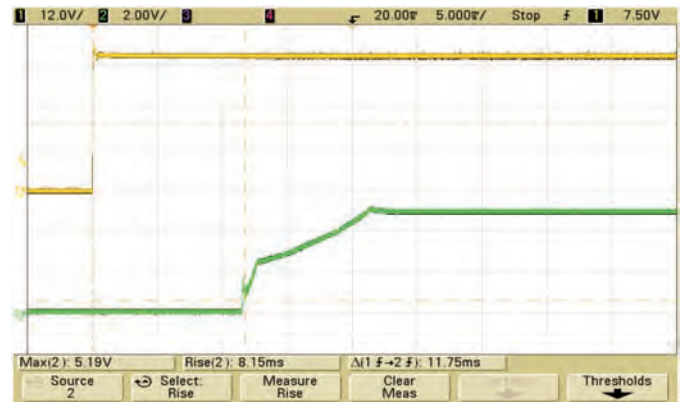

Figure 25. MTC7528S28 (25 °C) full resistive load - 11.9 ms

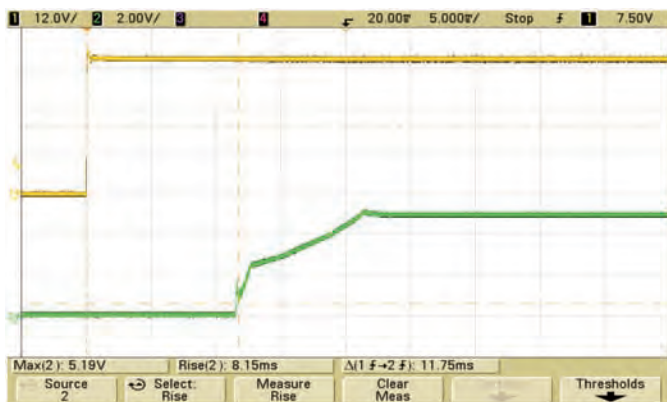

Figure 26. MTC7528S05 (25 °C) full resistive load and capacitor - 12.1 ms

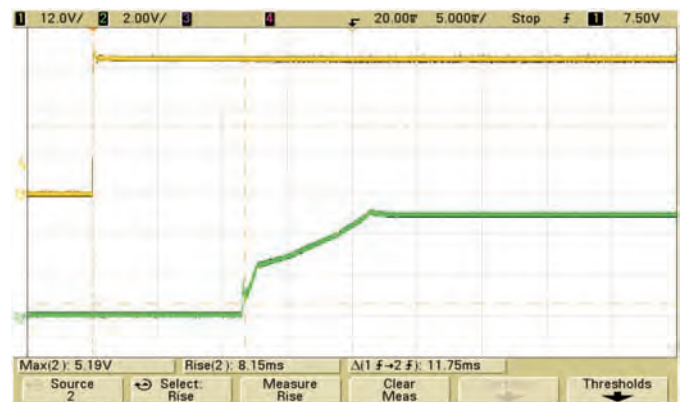

Figure 27. MTC7528S28 (25 °C) full resistive load and capacitor - 12.3 ms

Start Up - MTC150

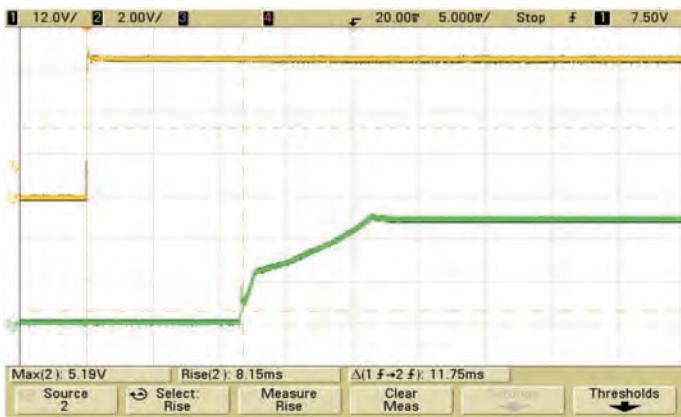

Figure 28. MTC15028S05 (25 °C) with full resistive load - 20.9 ms

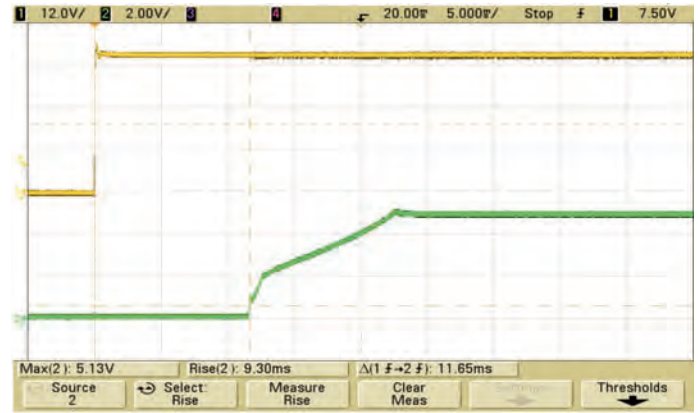

Figure 29. MTC15028S05 (25 °C) with full resistive load and capacitor - 22.2 ms

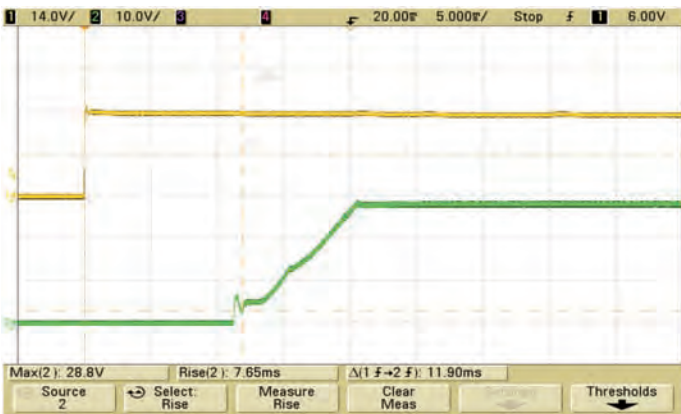

Figure 30. MTC15028S28 (25 °C) with full resistive load - 20.4 ms

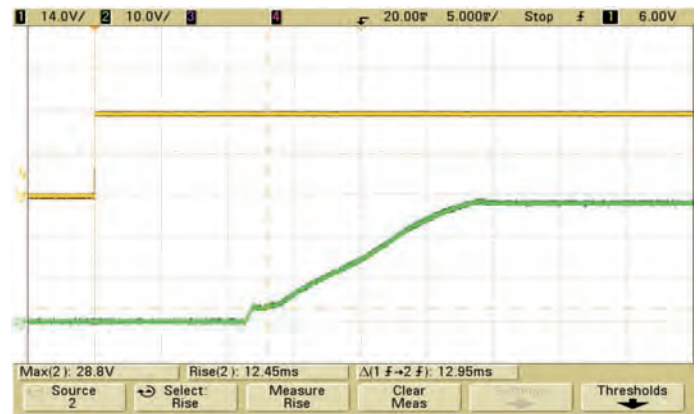

Figure 31. MTC15028S28 (25 °C) with full resistive load and capacitor - 28.5 ms

Dual Output Cross Regulation

MTC7528D12 - Iout1=70% combined load (4.38A); Iout2=variable (5% to 30%)

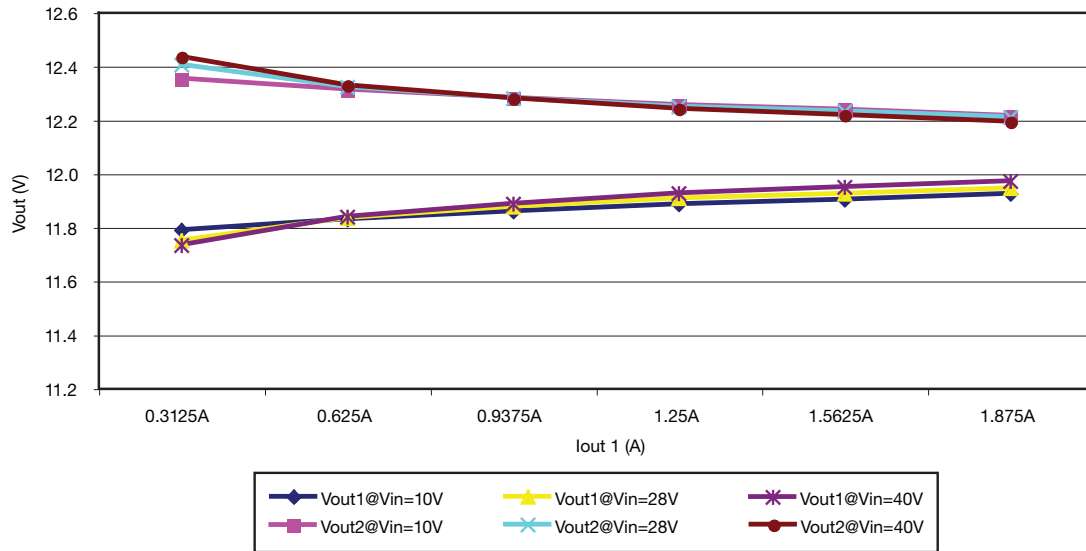

Figure 32. MTC7528D12 cross regulation

MTC7528D12 - Iout2=70% combined load (4.38A); Iout1=variable (5% to 30%)

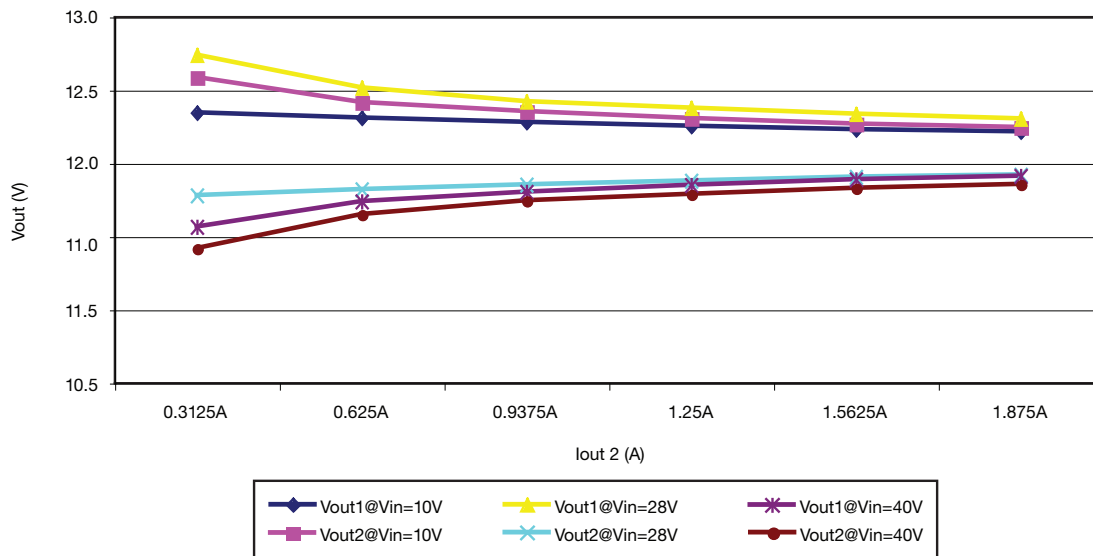

Figure 33. MTC7528D12 cross regulation

Dual Output Cross Regulation

MTC15028D12 - Iout1 = 70% combined load (8.75 A); Iout2 = variable (5% to 30%)

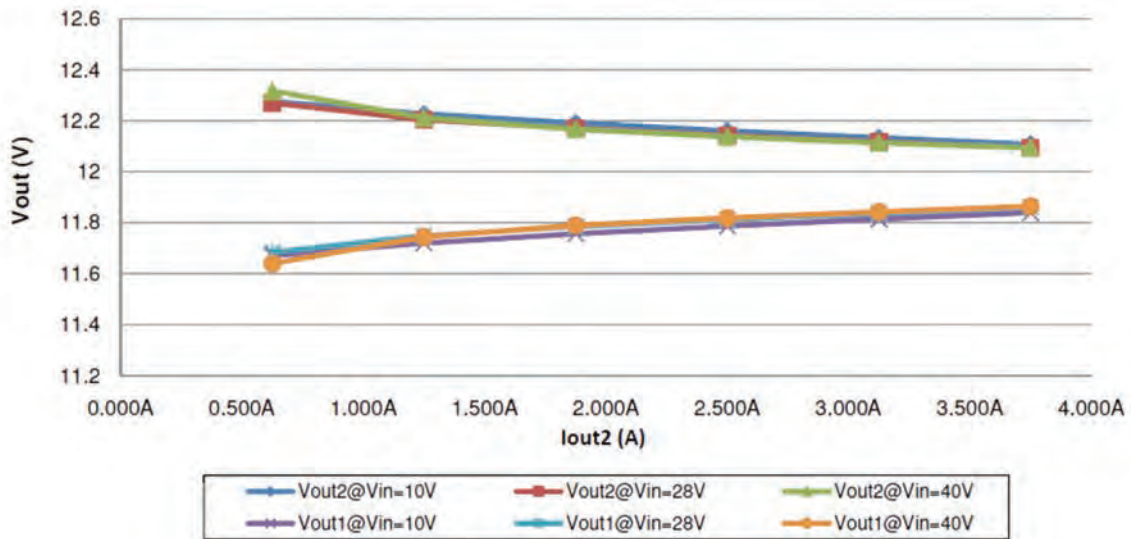

Figure 34. MTC15028D12 cross regulation

MTC15028D12 - Iout2 = 70% combined load (8.75 A); Iout1 = variable (5% to 30%)

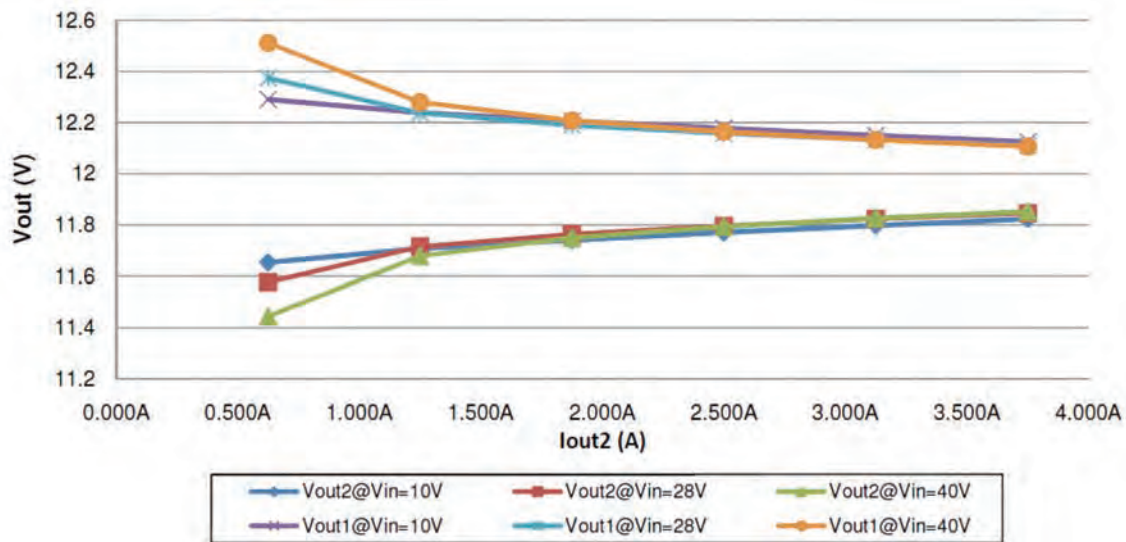
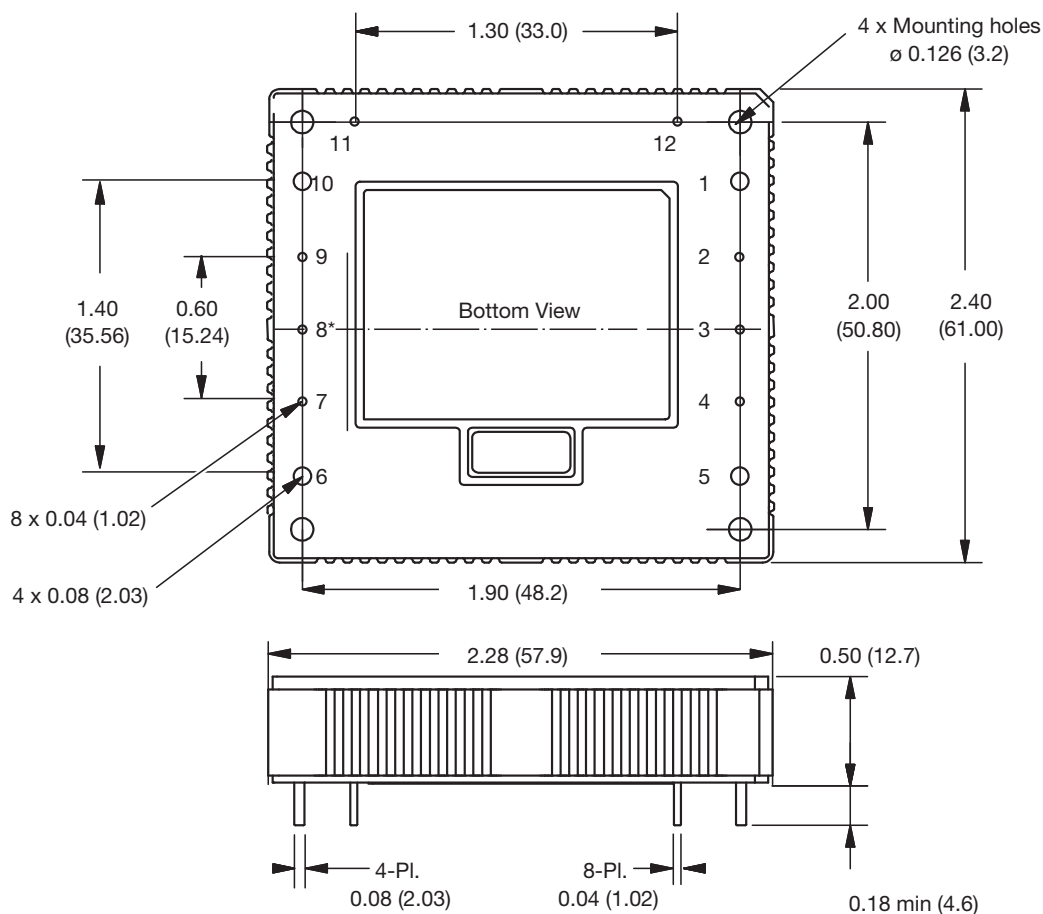

Figure 35. MTC15028D12 cross regulation

Mechanical Details



*On dual output versions, Pin 8 is 0.08 (2.03) Ø

Pin Connections					
Pin	Single Output	Dual Output	Pin	Single Output	Dual Output
1	+Vin	+Vin	7	-Sense	Trim
2	Remote On/Off	Remote On/Off	8*	Trim	Common
3	Thermal Warning (TW)	Thermal Warning (TW)	9	+Sense	No Pin
4	Case	Case	10	+Vout	+Vout
5	-Vin	-Vin	11	Share	No Pin
6	-Vout	-Vout	12	Synchronization	Synchronization

Notes

- Dimensions are in inches (mm)
- Tolerance: ± 0.02 inches (± 0.5 mm)
- Weight: 0.28 lb (128 g) approx

4. Materials & Finish:

Pin -

Material: Copper

Finish: Nickel plated 2.5 μm Ni and gold plated 0.3 μm Au.

Mounting Hole Diameter -

0.126 (3.2) clearance hole

Baseplate -

Material: Aluminium

Case -

Material: Non-conductive plastic