

FPK SERIES

Power Supply / Battery Charger: 500 ~ 1000 Watts

Application Notes:

1. General Description:

The FPK series power supply is available in 500W, 800W or 1000W that can be used as a power supply or combined Power Supply / Battery Charger unit.

Mounting:

The FPK power supplies series is designed to be secured via the mounting holes on the base plate. However, the module is inserted / removed (slides in) to the chassis see note 5.

Cooling: This power supply is fan cooled. The air intake is at the front panel and the exhaust is at the rear panel. Upon installation allow cooling air to reach the front panel ventilation inlets and allow minimum 50mm of unrestricted air space at the rear of the unit for the air exhaust.

AC Power Input: The FPK series can be operated from a nominal 100V to 240V, single phase, 47~63Hz.

Ensure that all connections are securely tightened before applying power. There is a potential shock hazard when using a power supply with a rated output greater than 40V.

2. Front Panel Control & Indicators.

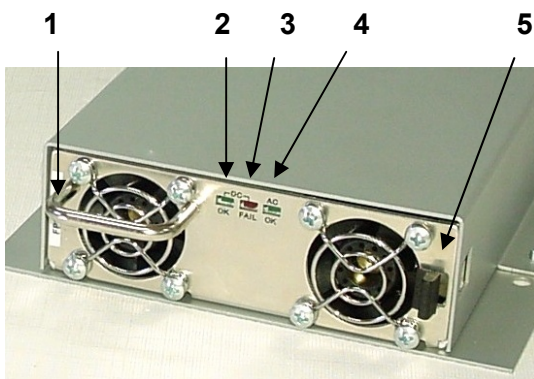

1. Handle. Allows for the power supply to be removed or inserted into the chassis.
2. DC OK green LED, ON when output voltage is above 80% ($\pm 5\%$) of nominal value.
3. DC FAIL red LED, ON when the output voltage is lower than 80% ($\pm 5\%$) of its nominal value.
4. AC OK green LED, ON when the input voltage is above 85VAC.
5. Lock / Unlock lever. Automatically locks the power supply to the chassis.

3. Rear Panel Connections.

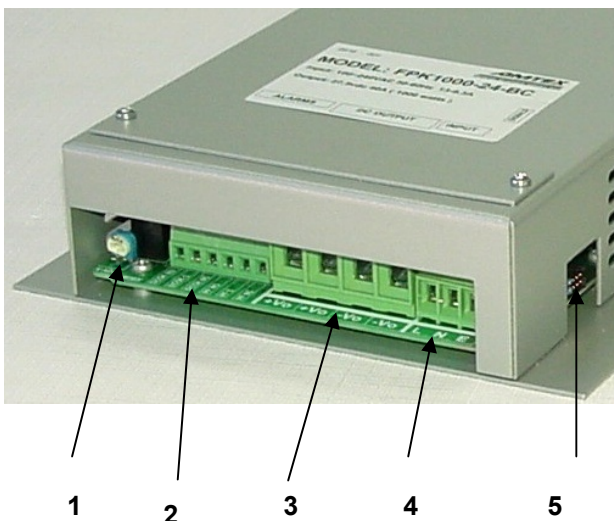

1. Access to output Voltage trim potentiometer
 2. **Alarm Signals :**
 - Power Fail Alarm relay (NC, COM, NO)
 - DC Fail Alarm relay (NC, COM, NO)
 3. **DC Power Output.** Two +VE and two -VE terminals.
 - For use as a combined Power Supply / Battery Charger, two terminals allocated for **Load** and two for **Battery** connections.
 4. **AC input** power terminals
 5. **Optional Signals** connector
- | | |
|-------|------------------------|
| Pin 1 | +12V Aux |
| Pin 2 | Vout TRIM (External) |
| Pin 3 | RTN |
| Pin 4 | Power Share |
| Pin 5 | RTN |
| Pin 6 | Over Temp |
| Pin 7 | RTN |
| Pin 8 | Remote ON / OFF |

4. Signals Connector.

Function	Description
ON / OFF Control (Optional Signals Connector)	The unit is normally shipped out with the ON/OFF link in place, allowing for the power supply to power ON when AC power is applied. The removal of this link allows for external ON/OFF control of this function by the RTN and ON/OFF terminals on the signals connector. Short = ON Open = OFF
DC OK	The DC_OK Remote Alarm, provides for external monitoring of DC Output Fail via a relay Output contacts. NO, Com, NC
AC Fail	The AC_Fail Remote Alarm, provides for external monitoring of AC power failure via a relay Output contacts. NO, Com, NC
Over Temp. Alarm (Optional Signals Connector)	Open collector signal, referenced to (Signal Return). On when the internal temperature is within safe limit, Off approx. 10C below Thermal shut down. The maximum sink current is 10mA and the maximum external voltage is 15V.
Voltage Trim	Output voltage trim is manually possible via an on-board trim pot located on the rear of the power supply It is also possible to Externally Trim the output voltage by TRIM pint and +VE and -VE output connector... <i>Consult office for details</i>
Power Share (Optional Signals Connector)	Two or more units can be connected in parallel for increased power or for N+1 Redundancy. The PSHARE pin / connection to be connected to the same pin on the next power supply unit.
12V 100mA Aux. (Optional Signals Connector)	Auxiliary voltage output, 11.2~12.5V, referenced to (Signal Return). The maximum load current is 0.25A. This output has built in Oring diode and is not controlled by the On/Off control.

4. Protection Features.

Over Voltage Protection: (OVP) The OVP triggers when the output voltage exceeds the maximum rating and reaches the OVP limit. When the OVP is triggered, the output voltage shuts down. In order to resume operation, the AC input voltage should be removed for more than 30 sec. The OVP level is factory set and is not adjustable.

Over Current Protection (OCP) A constant current limiting with automatic recovery is provided. The OCP operates when the output current exceeds 105%~125% of the rated output current. The output voltage recovers automatically when the overload condition is removed.

Over Temperature Protection (OTP) The OTP is activated when the ambient temperature or the power supply internal temperature exceeds a safe temperature. When the OTP is activated, the power supply output shuts down. The output recovers automatically when the ambient temperature or the internal temperature cools to a safe limit.

Over Temperature Alarm An open collector output provides an Over Temperature Alarm approx. 10C below shut down by the OTP. The open collector output is referenced to the Signals Return potential and is isolated from the power supply +V and -V terminals. The maximum sink current is 10mA and the maximum external voltage is 15V.

5. Basic Connection: Single AC/DC Power Supply:

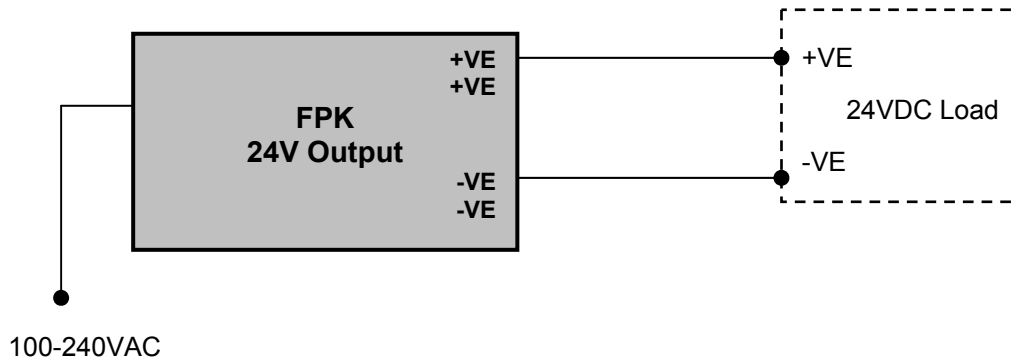

6. Combined Power Supply / Battery Charger

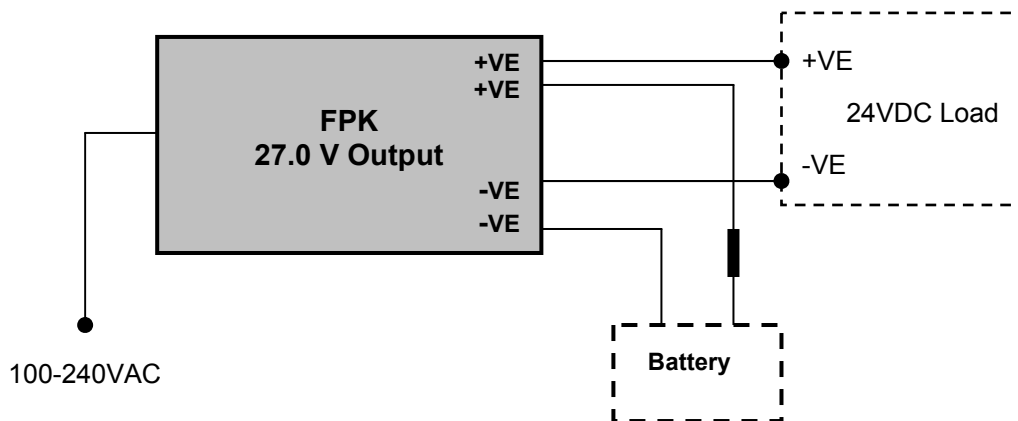

Notes:

- a) External Battery protection device must be connected for Battery Protection.
- b) Output voltage must be set for correct battery float voltage.

7. **FPS Maintenance**

Units under warranty requiring repairs during the warranty period should be returned to our office for service. Unauthorized repairs performed by other than the authorized service facilities may void the warranty.

Periodic maintenance. No routine maintenance of the FPK power supply is required except for periodic cleaning. To clean, disconnect the unit from the AC supply and allow 30sec. for discharging internal voltage. The FPK should be cleaned using mild solution of detergent and water. The solution should be applied onto a soft cloth, and not directly to the surface of the unit. Do not use aromatic hydrocarbons or chlorinated solvents for cleaning. Use low pressure compressed air to blow dust from the unit.

Fan life expectancy. The fan life has limitation depending mainly on the ambient temperature.