





DLP Series Instruction Manual

BEFORE USING THE POWER SUPPLY UNIT

Pay attention to all warnings and cautions before using the unit. Incorrect usage could lead to an electrical shock, damage to the unit or a fire hazard.

- **Warning Symbols**

CAUTION	
• DO NOT MODIFY, DISASSEMBLE THE POWER SUPPLY.	
• HOT SURFACE.	
• READ INSTRUCTION MANUAL BEFORE CONNECTING TO MAINS.	
• ELECTRIC SHOCK HAZARDOUS ON THE CONNECTOR SECTION.	

NOTICE:

(1) Installing/Storage Environment

1. Store the product with ambient temperature -30 to $+85$ °C, and relative humidity 10 to 95% (No Dewdrop).
2. Never operate the unit under over current or shorted conditions for 30 seconds or more and out of Input Voltage Range in specification which could result in damage or insulation failure or smoking or burning.
3. Confirm connections to input/output terminals are correct as indicated in the instruction manual.
4. Use the product where the relative humidity is 30 to 90% (No Dewdrop).
5. Avoid places where the product is subjected to direct sun light.

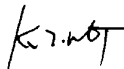
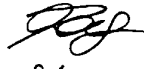
DWG NO. : CA733-04-01		
APPD	CHK	DWG
 29. May. 2003	 28/May/03	Peng 28-May-'03

6. Avoid penetration of metal chips when processing mounting holes.
7. Avoid places where the products is subjected to penetration of liquid, foreign substance, or corrosive gas.
8. Avoid places subject to shock or vibration.

A device such as a contact breaker may be a vibration source. Set the Power Supply as far as possible from possible sources of shock or vibration.

9. If the Power Supply is used in an area with excessive electronic noise, be sure to separate the Power Supply as far as possible from the noise sources.

Precautions in Using the product:

When the product is used under the circumstance or environment below, ensure adherence to limitations of the ratings and functions.

Also take countermeasures for safety precautions such as fail-safe installations.

1. Under the circumstances or environment which are not described in the instruction manual.
2. For nuclear power control, railway, aircraft, vehicle, incinerator, medical equipment, entertainment equipment, safety device etc...
3. For applications where death or serious property damage is possible and extensive safety precautions are required.
4. Terminal block covers are necessary to be used when connecting the input and output wire. (N/A on -EJ models)
5. Don't recommend using input power source with large inductance, which may cause power supply operate unstably.
6. DLP180/E and DLP240/E are capable of providing hazardous energy output (240VA), the end equipment manufacturer must provide protection to service personal against inadvertent contact with output terminals. These terminals must not be user accessible.

Note: CE MARKING

CE Marking, when applied to a product covered by this handbook indicates compliance with the low voltage directive (73/23/EEC) as modified by the CE Marking Directive (93/68/EEC) in that it complies with EN60950.

1. Terminal Explanation

1-1.1 DLP75

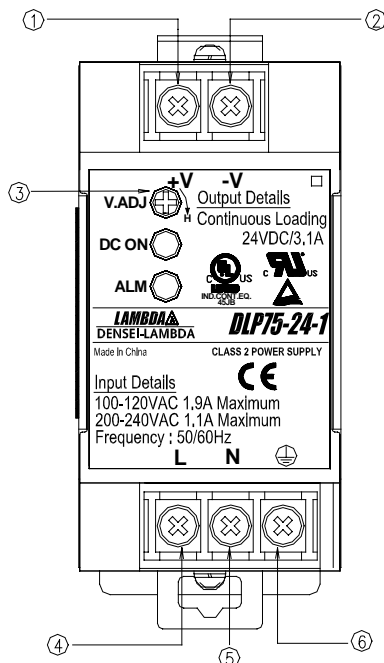

1-1.2 DLP75/EJ

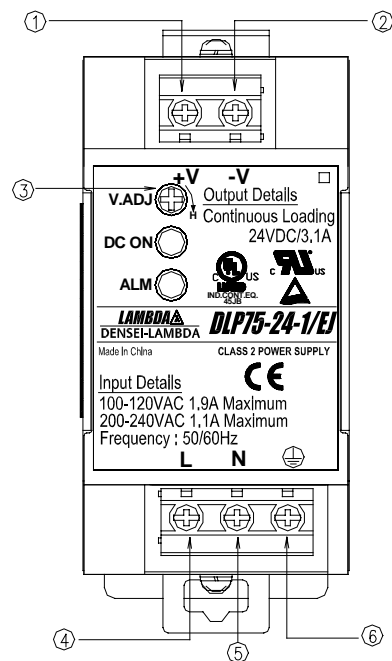

DENSEI-LAMBDA

DLP Series

INSTRUCTION MANUAL

- ① +V: +Output terminal
- ② - V: - Output terminal
- ③ V.ADJ: Output voltage adjust trimmer
The output voltage rises when a trimmer is turned clockwise.
- ④ L: AC Input terminal
Live line (fuse in line)
- ⑤ N: AC Input terminal
Neutral line
- ⑥ FG: Input terminal FG
Safety earth (Frame Ground)
Connect to safety ground of apparatus or equipment.

1-2.2 DLP120/EJ

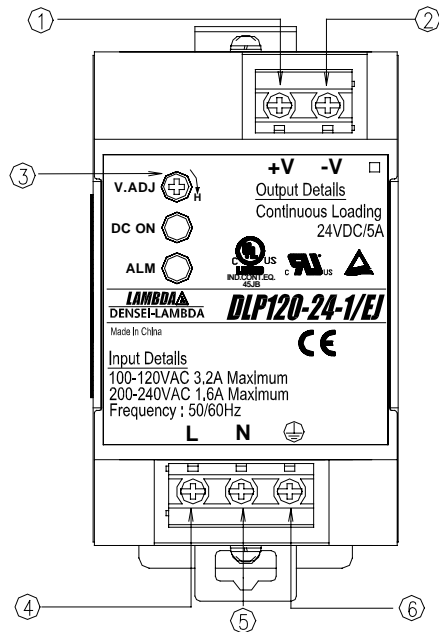

1-2.1 DLP120

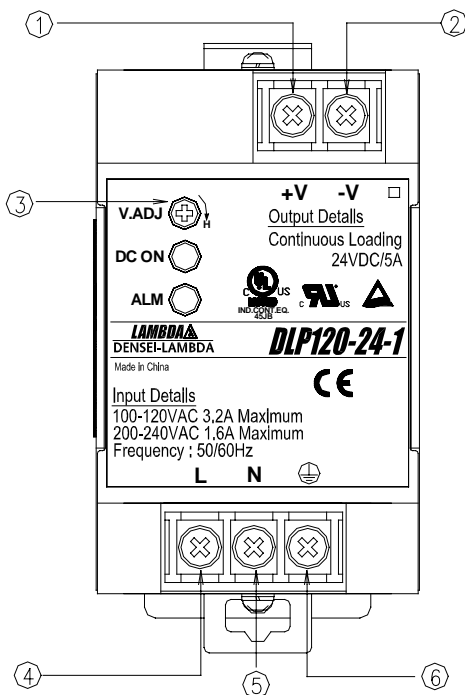

1-2.3 DLP100

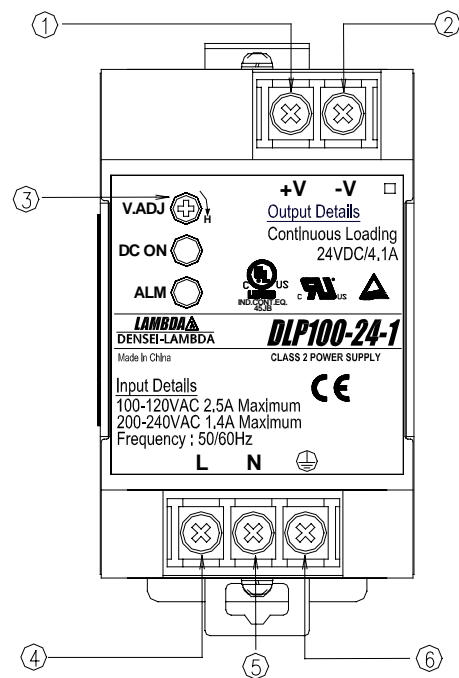

1-2.4 DLP100/EJ

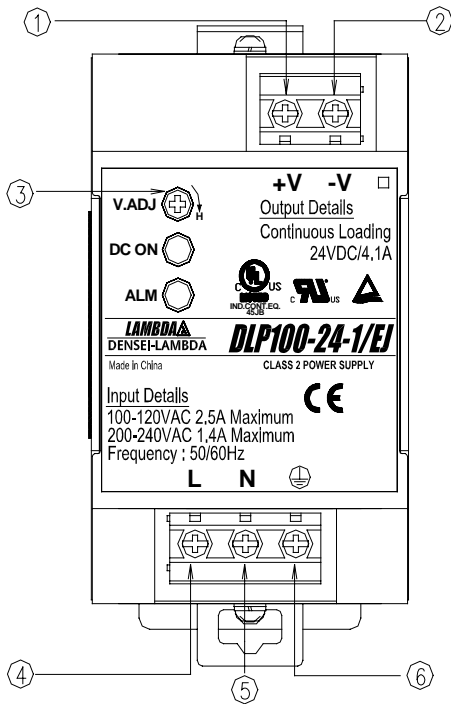

1-3.1 DLP180

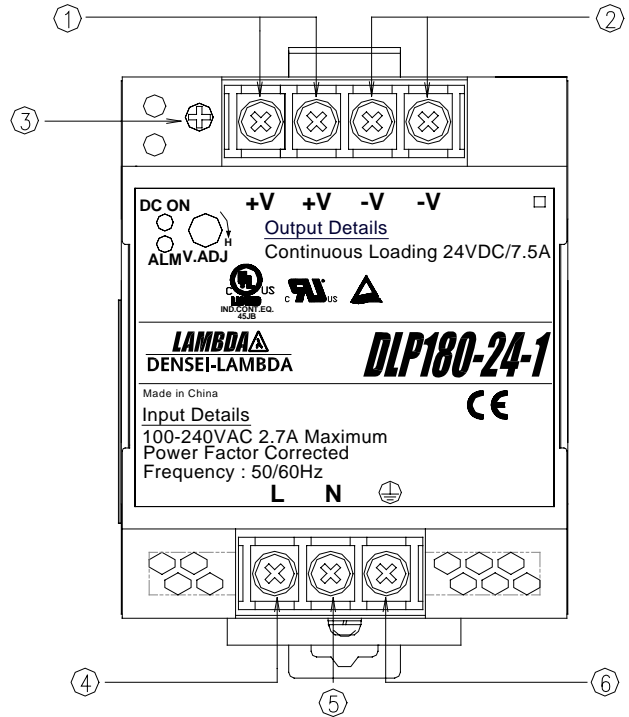

1-3.2 DLP180/EJ

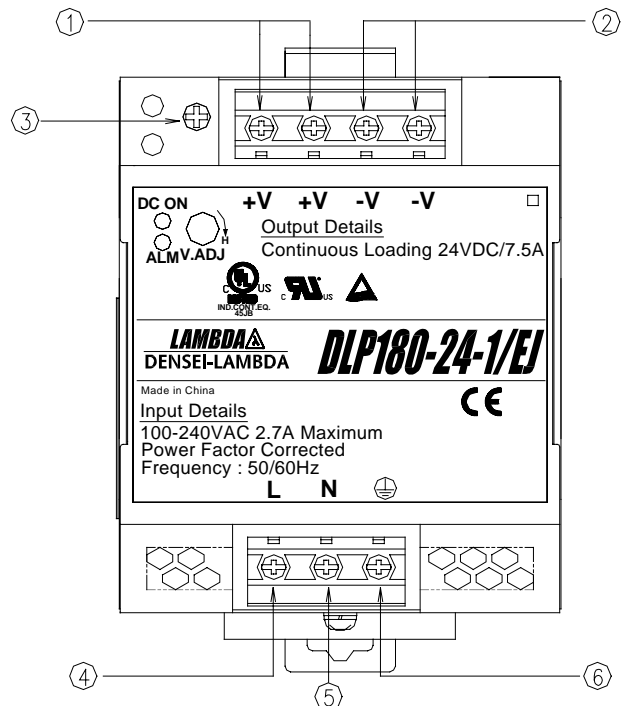

- ① +V: +Output terminal
- ② - V: - Output terminal
- ③ V.ADJ: Output voltage adjust trimmer
The output voltage rises when a trimmer is turned clockwise.
- ④ L: AC Input terminal
Live line (fuse in line)
- ⑤ N: AC Input terminal
Neutral line
- ⑥ FG: Input terminal FG
Safety earth (Frame Ground)
Connect to safety ground of apparatus or equipment.

1-4.2 DLP240/EJ

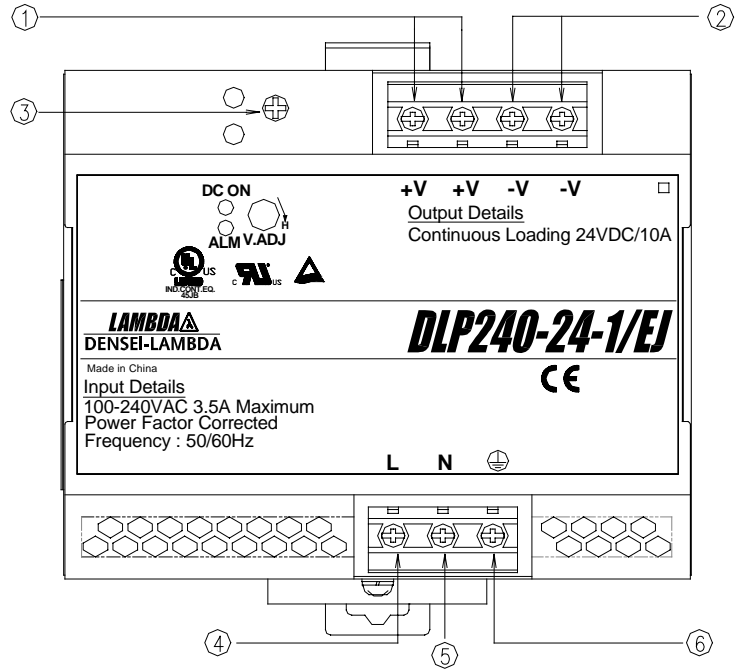

- ① +V: +Output terminal
- ② - V: - Output terminal
- ③ V.ADJ: Output voltage adjust trimmer
The output voltage rises when a trimmer is turned clockwise.
- ④ L: AC Input terminal
Live line (fuse in line)
- ⑤ N: AC Input terminal
Neutral line
- ⑥ FG: Input terminal FG
Safety earth (Frame Ground)
Connect to safety ground of apparatus or equipment.

1-4.1 DLP240

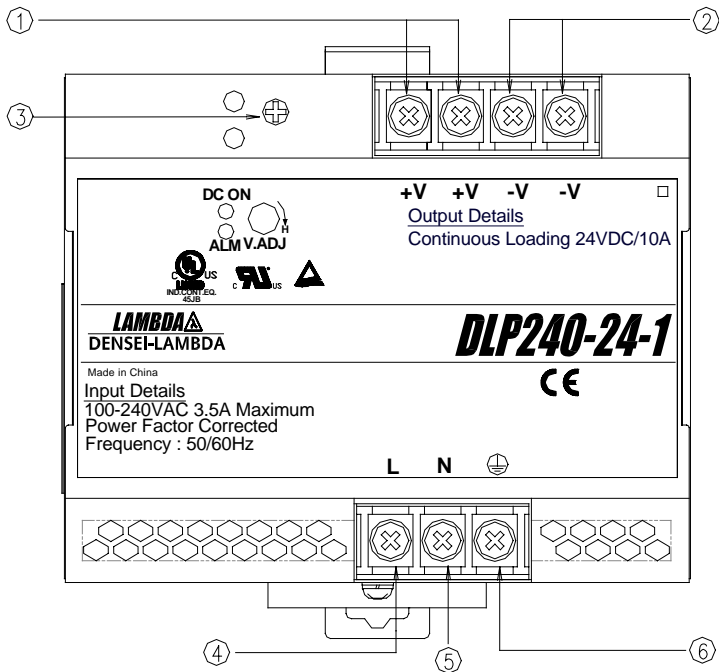

- ① +V: +Output terminal
- ② - V: - Output terminal
- ③ V.ADJ: Output voltage adjust trimmer
The output voltage rises when a trimmer is turned clockwise.
- ④ L: AC Input terminal
Live line (fuse in line)
- ⑤ N: AC Input terminal
Neutral line
- ⑥ FG: Input terminal FG
Safety earth (Frame Ground)
Connect to safety ground of apparatus or equipment.

2. Terminal Connecting Method

Pay attention to the input wiring. If it is connected to wrong terminal, the power supply will be damaged.

- Input must be off when making connections.
- Connect FG terminal of input connector and mountable FG to ground terminal of the equipment.
- The output load line and input line shall be separated and twisted to improve noise sensitivity.
- When connecting or removing input and output wire, do not apply stress to PCB.

2-1.2 DLP75/EJ

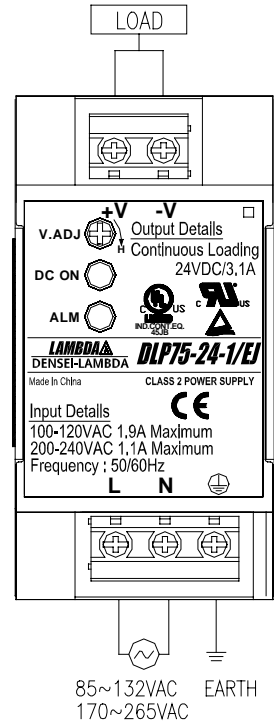

2-1.1 DLP75

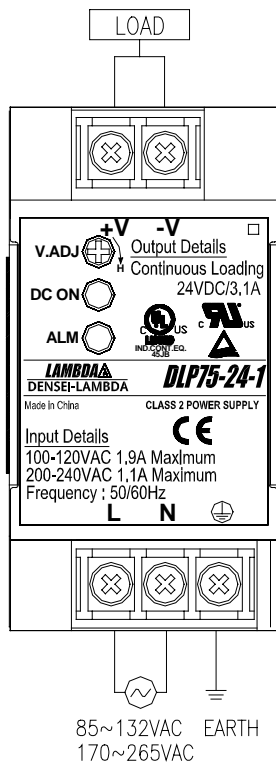

2-2.1 DLP120

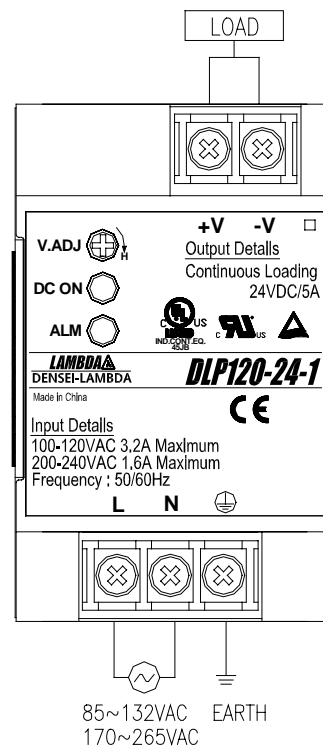

2-2.2 DLP120/EJ

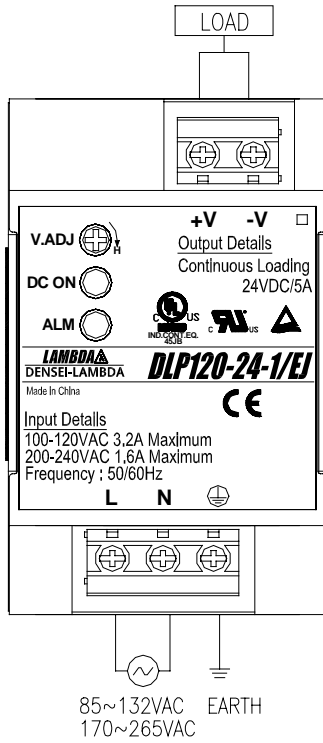

2-2.4 DLP100/EJ

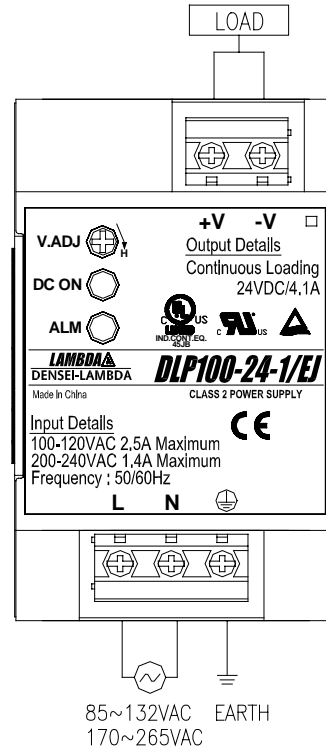

2-2.3 DLP100

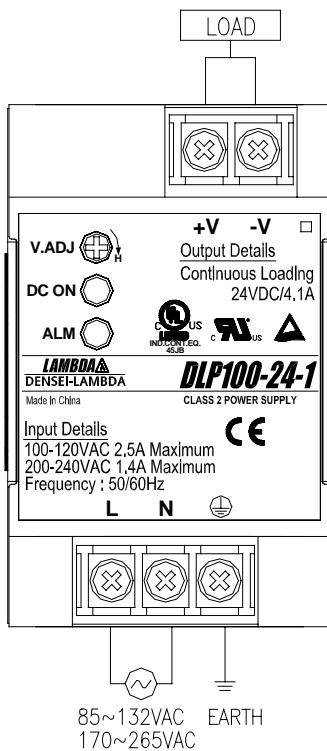

2-3.1 DLP180

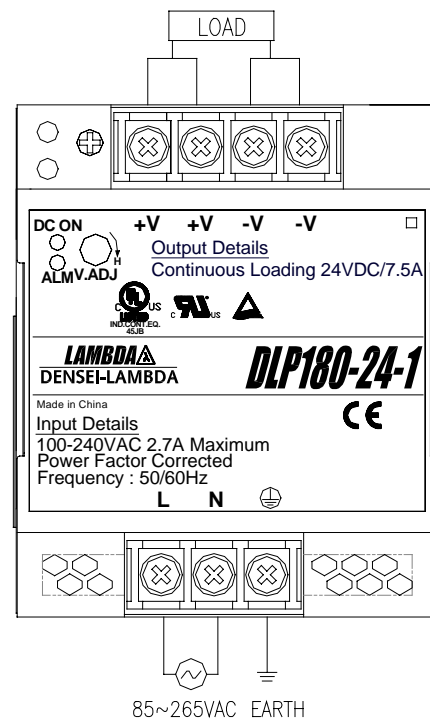

2-3.2 DLP180/EJ

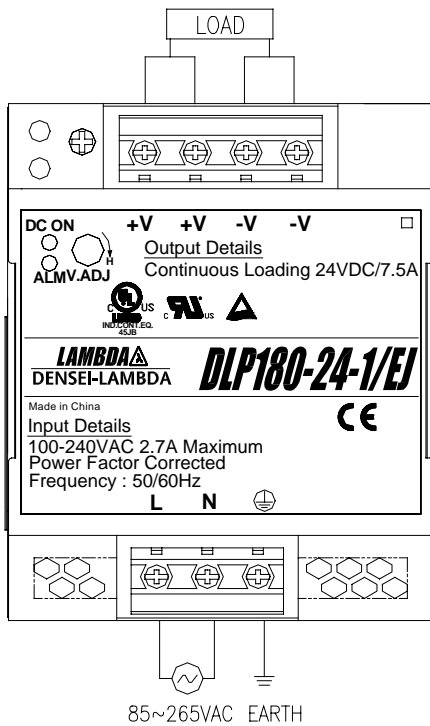

2-4.3 DLP240/EJ

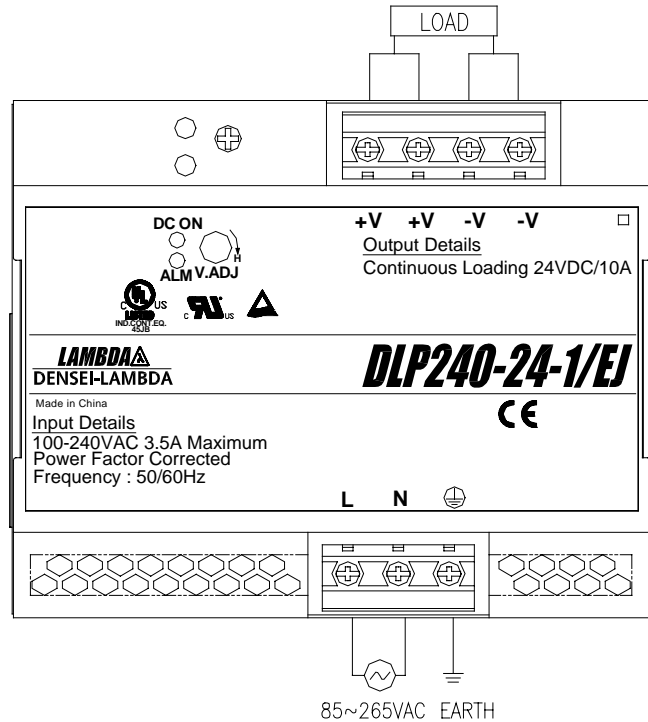

2-4.1 DLP240

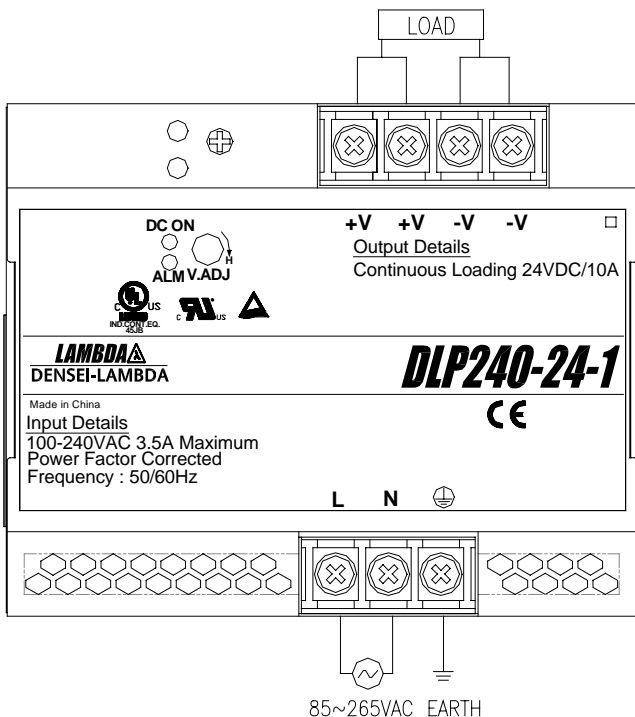

3. Explanation of Functions and Precautions

3-1. Input Voltage Range

Input voltage range is single phase 85 ~ 132VAC/ 170 ~ 265VAC (47 ~ 63Hz) (DLP75, DLP100, DLP120 series) or 85 ~ 265VAC (DLP180, DLP240 series). Input voltage which is out of specification may cause unit damage. For cases where conformance to various safety specs (UL,CSA,EN) are required, input voltage range will be 100 ~ 120VAC/200 ~ 240VAC (50/60Hz) (DLP75, DLP100, DLP120 series) or 100 ~ 240VAC (50/60Hz) (DLP180, DLP240 series). Do not switch input voltage from 85~132VAC directly to 170~265VAC, as may cause power supply damaged (DLP75, DLP100, DLP120 series).

3-2. Output Voltage Range

V.ADJ trimmer is for output voltage adjustment within the range of specifications (21.6 ~ 28V). To turn the trimmer clockwise, the output voltage will be increased. Note over voltage protection (OVP) function may trigger if the output voltage is increased excessively.

3-3. Inrush Current

This series has used Power Thermistor to protect the circuit from Inrush Current. Please carefully select input switch and fuse in cases of the high temperature and re-input the power.

3-4. Over Voltage Protection (OVP)

The OVP function (Inverter shut down method, manual reset type) is provided. OVP function operates within the range of OVP specification (30 ~ 35V).When OVP triggers, the output will be shut down. The input shall be removed for a few minutes, and then re-input for recovery of the output. OVP setting is fixed and not to be adjusted externally.

3-5. Over Current Protection (OCP)

Constant current limiting (except DLP75 series, which characterized as fold back), automatic recovery. OCP function operates when the output current exceeds OCP specification. The output will be automatically recovered when the overload condition is cancelled. Do not operate overload or dead short conditions for more than 30 seconds, which could result in damage or insulation failure. DLP75 series models are not recommended for constant current load application.

3-6. Output Ripple & Noise

The standard specification for maximum ripple value is measured according to measurement circuit specified by JEITA-RC9131. When load lines are longer, ripple becomes larger. In this case, electrolytic capacitor, film capacitor, etc. might be necessary to use across the load terminal. The output ripple cannot be measured accurately if the probe ground lead of oscilloscope is too long.

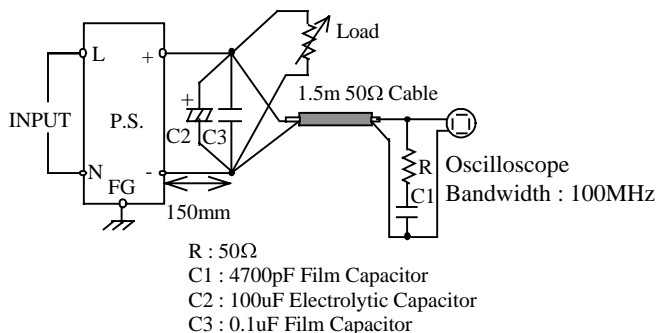

3-7. Series Operation

For series operation, either method (A) or (B) is possible.

Method (A)

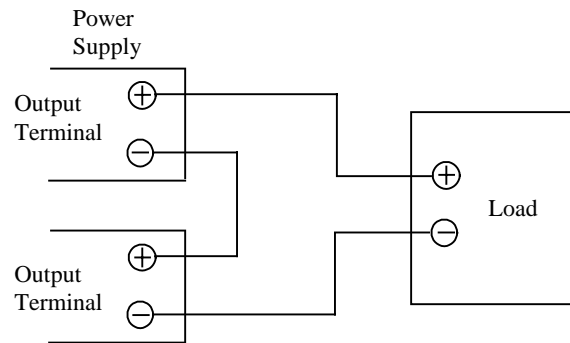

Method (B)

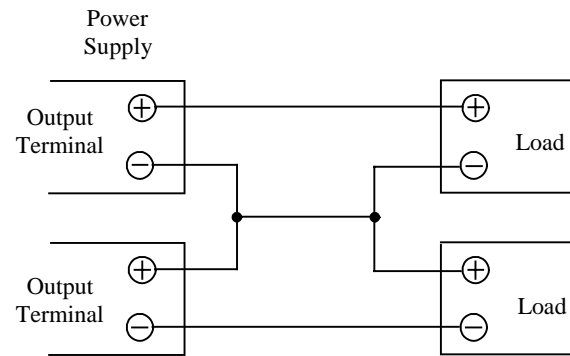

3-8. Parallel Operation

(A) To increase the output current is not possible.

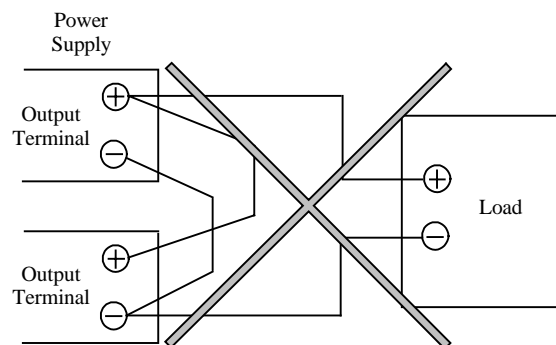

(A) To use as Back-up Power Supply

1. Set power supply output voltage higher by the forward voltage drop(VF) of diode
2. Adjust the output voltage of each power supply to be the same.
3. Use within the specifications for output voltage and output power.

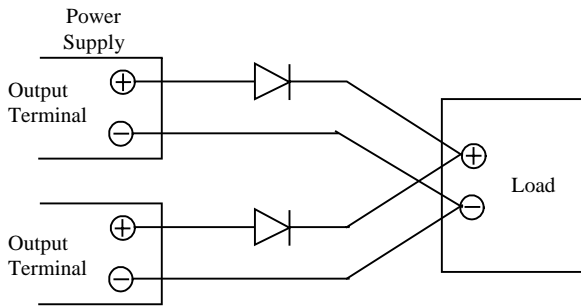

3-9. Isolation Test

Isolation resistance between output and FG (Chassis) shall be more than 100MΩ at 500VDC. For safety operation, voltage setting of DC isolation tester must be done before the test. Ensure that the it is fully discharged after the test.

Output – FG (Chassis)
 500VDC 100MΩ or more

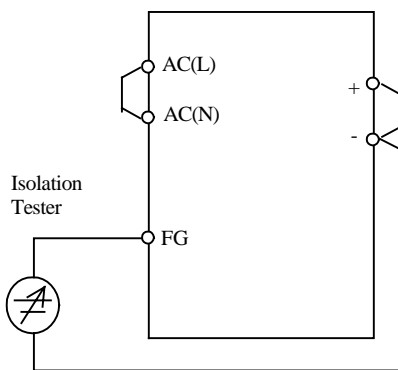

3-10. Withstand Voltage

This series is designed to withstand 3.0kVAC between input and output, 2.0kVAC between input and FG (Chassis) and 500VAC between output and the FG (Chassis) each for 1 minute. When testing withstand voltage, set current limit of the withstand voltage test equipment to 20mA (Output - FG (Chassis) : 100mA). The applied voltage must be gradually increased from zero to the testing value and then gradually decreased for shut down. When timer is used, the power supply may be damaged by high impulse voltage at timer switch on and off. Connect input and output as follows.

Input ~ Output (dotted line)
 3kVAC 1min. (20mA)
 Input ~ FG (Chassis) (solid line)
 2kVAC 1min. (20mA)

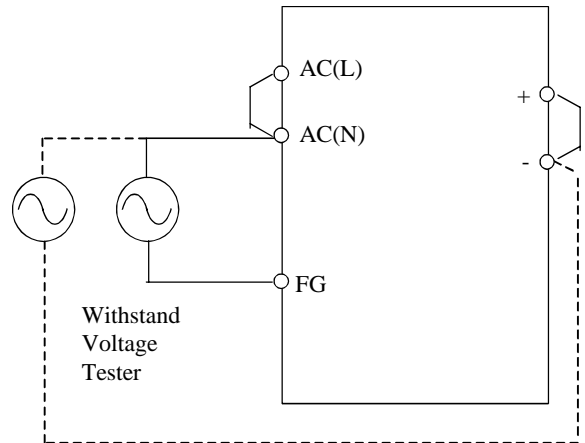

Output ~ FG (Chassis)
 500VAC 1min. (100mA)

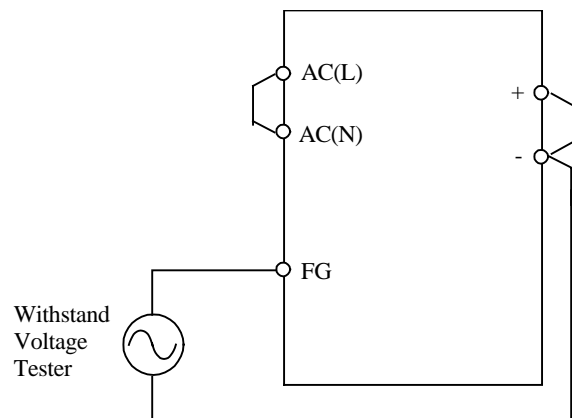

3-11. Alarm Indication

LED on the panel indicate whether the power supply unit is working properly.

- The green LED is on and red LED is off in normal operation.
- The red LED turns on when O/P voltage drops below approximately 20V (ex: over current protection, output voltage unregulated, output shorted conditions).
- The green LED goes out when output shorted (output voltage below 2V).
- Both LEDs turn off on the condition of input power source failure or power supply damaged.

4. Mounting Directions

4-1. Output Derating according to the Mounting Directions

Recommended standard mounting method is (A). Please do not use installation method (B). Refer to the derating below. Do not exceed the load deratings.

DENSEI-LAMBDA DLP Series INSTRUCTION MANUAL

Normal mounting (A)

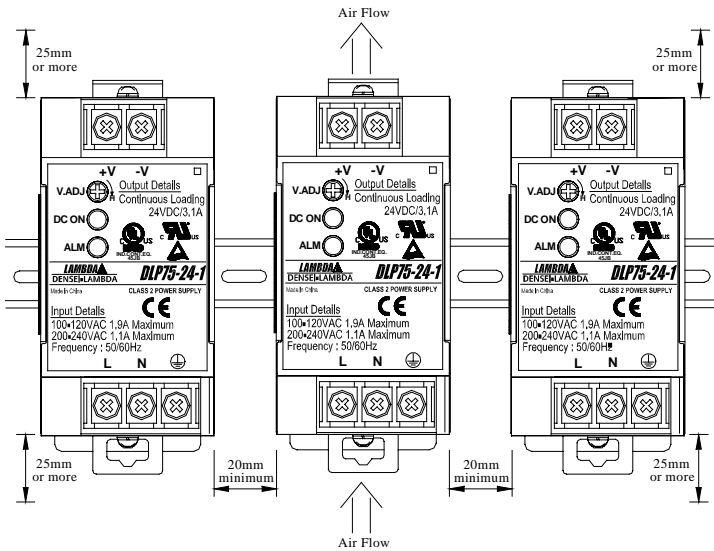

DLP100, DLP100/EJ

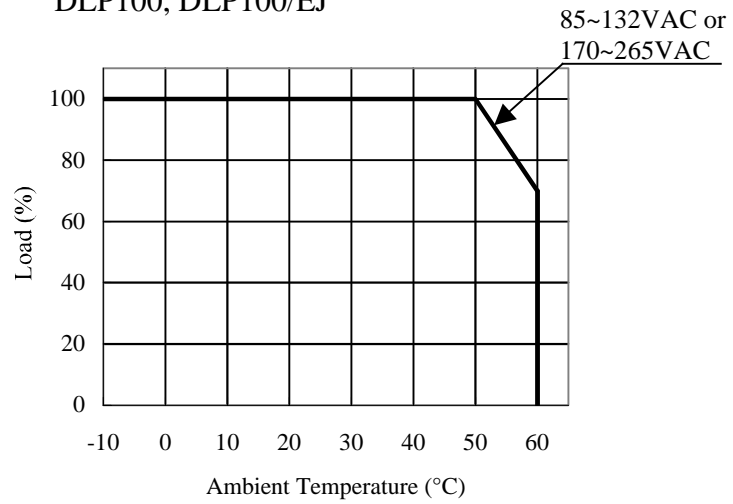

Back Down Mounting (B)

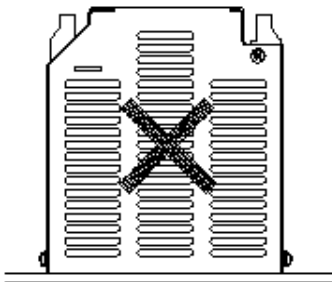

DLP180, DLP180/EJ

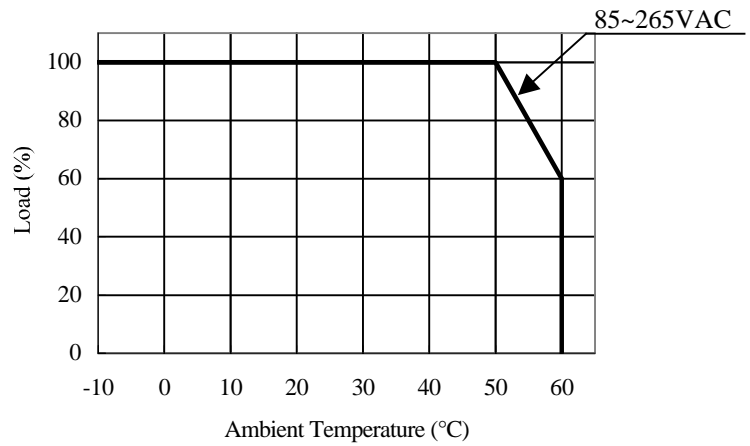

Output Derating

DLP75, DLP75/EJ, DLP120, DLP120/EJ

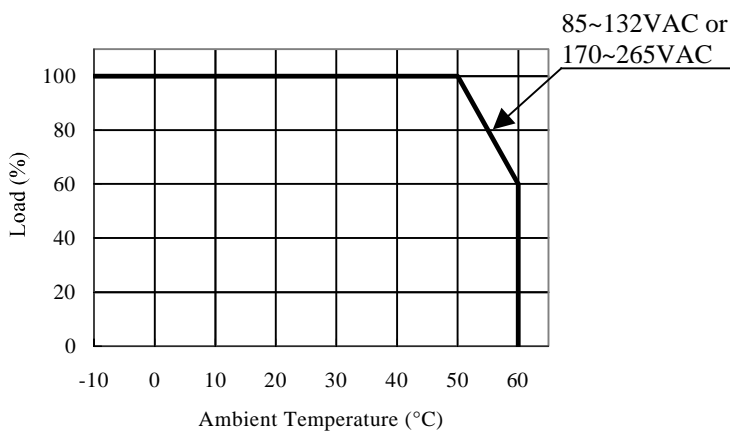

DLP240, DLP240/EJ

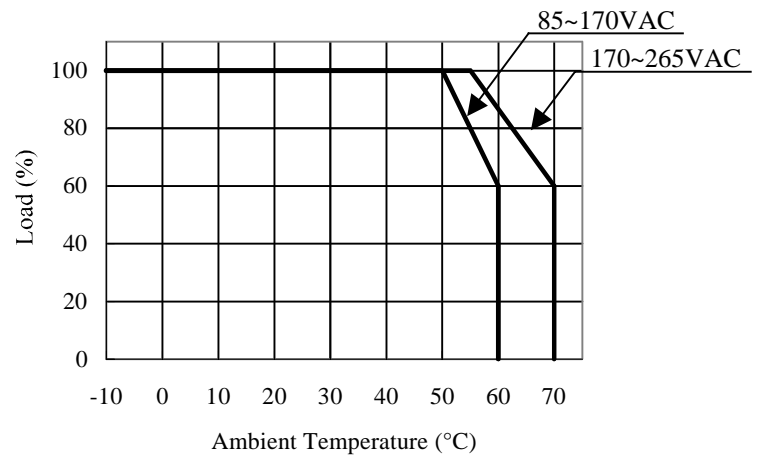

5. Wiring Method

- The output load line and input line shall be separated and twisted to improve noise sensitivity.
- Use all lines as thick and short as possible to make lower impedance.
- Noise can be eliminated by attaching a capacitor to the load terminals.
- EMI reduction performance by winding the cable around the toroidal ferrite core several times. Use any appropriate commercially available ferrite core from local vendor.
- For safety and EMI considerations, connect FG terminal of input connector and mountable FG to ground terminal of equipment.
- Recommended screw torque is 1.27N.m (DLP), 0.49N.m (DLP/EJ).
- Recommended wire type: solid and stranded, AWG 12~20 (wire strip length: 6~7mm for DLP/EJ models).
- For case to meet EN60529 IP20, use the following wiring method to prevent from electrical shock. (DLP standard models).

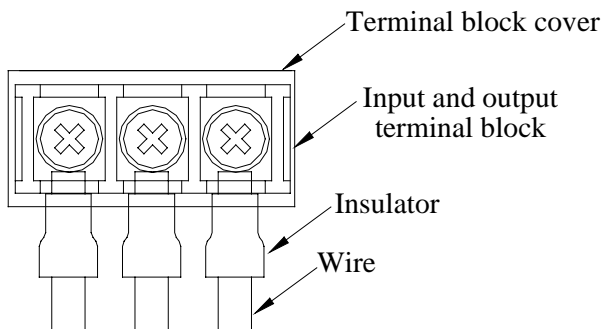

6. External Fuse Rating

Refer to the following fuse rating when selecting the external fuses that are to be used on input line. Surge current flows when line turns on. Use slow-blow fuse or time-lag type fuse. Do not use fast-blow fuse. Fuse rating is specified by in-rush current value at line turn-on. Do not select the fuse according to input current (rms.) values under the actual load condition.

DLP75, DLP75/EJ	5A
DLP100, DLP100/EJ	5A
DLP120, DLP120/EJ	5A
DLP180, DLP180/EJ	5A
DLP240, DLP240/EJ	6.3A

7-1. Power supply mounting on DIN RAIL (TS35 or equivalent)

- (1) Tilt the unit slightly rearwards, fit the unit over top hat rail.

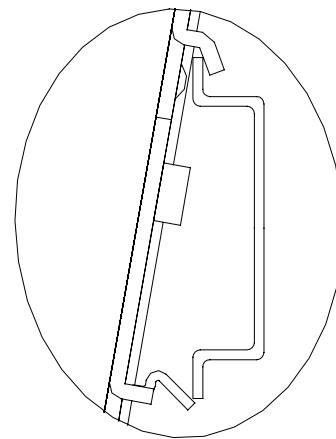
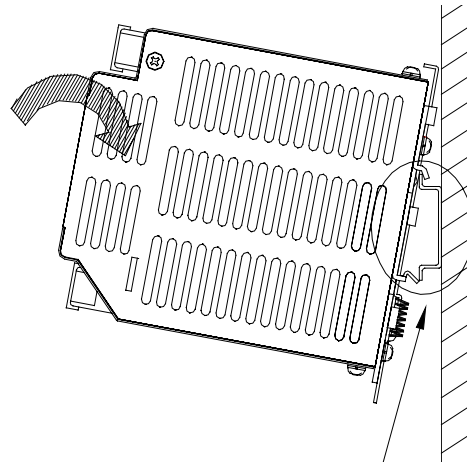

- (2) Slide it downward until it hits the stop.

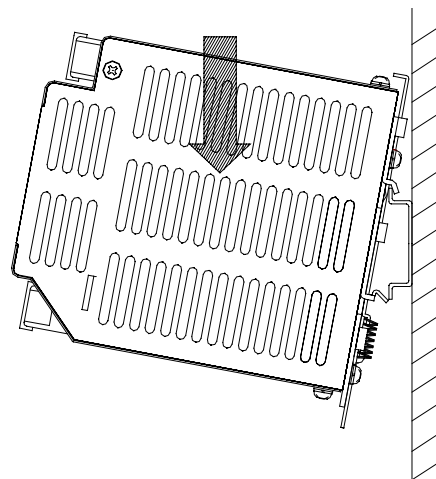

- (3) Press against the bottom front side for locking.
Shake the unit slightly to check the locking action.

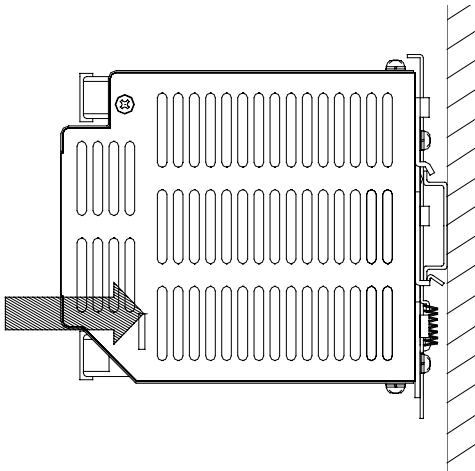

- (4) In order to tighten the unit mounting, the Din rail stopper attached on both sides of the unit is recommended.

7-2. Power supply removal from DIN RAIL

- (1) Switch main power off and disconnect your system from the supply network. Push the button on the rear upper edge of the unit or move the removal hole on the rear down edge downwards by screw driver. Gently lift lower front edge of the unit (tipping) and remove it.

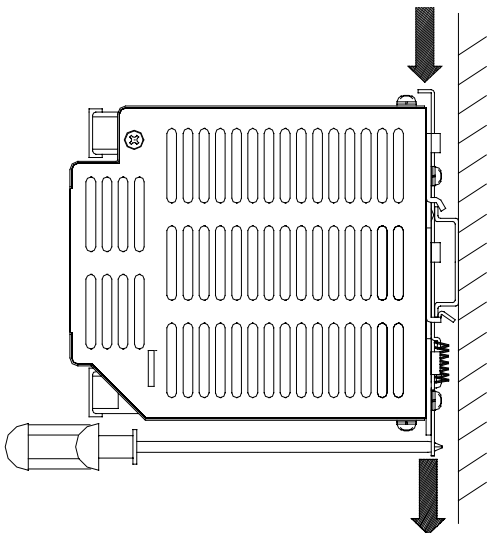

8. Before concluding that the unit is at fault...

Before concluding that the unit is at fault, make the following checks.

- Check if the rated input voltage is connected.
- Check if the wiring of input and output is correct.
- Check if the wire material is not too thin.
- Check if the output voltage control (V.ADJ) is properly adjusted.
- Check if the output current and output wattage do not over specification.
- Audible noise can be heard during Dynamic-Load operation.
- Audible noise can be heard when input voltage waveform is not sinusoidal wave.

9. Notes

- 1) Meet EN50178 over voltage Category III (Primary).
Over voltage Category II (Secondary).
- 2) DLP75, DLP75/EJ, DLP100, DLP100/EJ are categorized as class2 power supply source.
- 3) Radio Interference Suppression Test is not performed.

10. Repair

**In case of damage or repair of this product,
please return to our service center or factory.**